

# LAMOT®

## Product Selection Guide

L-1000-1

Represented by:



1185 Tower Road  
Schaumburg, IL 60173  
Ph: 847.885.0300 Fax: 847.885.0303  
lindenequipment.com



# LAMOT®

## LAMOT FOR QUALITY

Since 1964, the LAMOT brand of rupture discs and rupture disc holders have been manufactured using proven techniques, industry standards, and modern manufacturing methods. As a customer, we know you expect both product quality and dependable service. When you choose LAMOT, this is precisely what you receive. All manufacturing is performed under an approved ISO 9001 Quality Assurance System to assure that rupture discs and holders are built to exacting specifications. Our sales people are ready to offer immediate assistance when you need an answer, have a problem to solve, or an order to place.

When you choose the LAMOT brand, there are three advantages you can count on with every order:

- Quick delivery
- Competitive price
- Quality

Rupture disc holders are manufactured using computer controlled equipment, thus ensuring quality finishes and dimensional accuracy. Our rupture discs are manufactured from a variety of metals which are purchased according to closely controlled specifications.

Special metal forming techniques and state-of-the-art pressure indicators insure very accurate recorded rupture pressures. This, in combination with our years of manufacturing experience and dedication to quality, is assurance of precision performance from LAMOT products.

Your inquiries about rupture disc applications requiring special designs are encouraged.

# LAMOT®

## LAMOT RUPTURE DISCS

LAMOT brand tension type rupture discs are manufactured for a wide range of rupture disc holder configurations. These rupture discs include both Standard and Composite designs.

### What is a Standard Type Rupture Disc?

The Standard Rupture Disc is a solid metal, prebulged (preformed) differential pressure relief device. It is widely used in industry to protect equipment, vessels, and systems from an overpressure condition. The rupture disc provides instantaneous full-opening within milliseconds of an overpressure situation. LAMOT's Standard Rupture Disc provides performance under pressure and is the guardian of the system.



The Standard Rupture Disc is usually used in systems that have an operating pressure of up to 70% of the rupture disc's rated burst pressure. Under ideal operating conditions, such as static pressure with operating temperatures that are well below the maximum recommended temperatures for the rupture disc material being used, the Standard Rupture Disc may be subjected to operating pressures in excess of 70% of the rated burst pressure. Consult your local representative or the factory for detailed information about the use of the Standard Rupture Disc at operating pressures greater than 70% of the rated burst pressure. The minimum and maximum burst pressures for the Standard Rupture Disc are found in Table IV.

### Sizes and Materials

The 30° angular seat design Standard Rupture Disc is available in nominal sizes 1/2" through 12" (13 - 300 mm) for use in Full Bolted, Insert, and Union rupture disc holders. Pressure ranges from 3 psig to 6,000 psig (0,207 - 414 barg) are available in a variety of different materials. Depending on the material of construction, this rupture disc will perform at temperatures up to 1,000°F (538° C) and resist most corrosive media and atmospheric conditions. The Standard Rupture Disc is suitable for either gas or liquid applications. Refer to Table II for recommended maximum operating temperatures of Standard Rupture Disc materials.

### Corrosion Protection

When a rupture disc is subjected to corrosive elements from either the media or atmospheric side, LAMOT offers both protective liners and coatings to help eliminate the effect corrosives might have on the performance of the rupture disc. Typically, liners are made of Teflon®\*.

\* TEFLON is a registered trademark of E.I. du Pont de Nemours and Company used under license.

Top left cover photo courtesy of Air Liquide America; Houston, Texas.

## What is a Composite Type Rupture Disc?

A Composite Rupture Disc is a differential pressure relief device used for protecting equipment, vessels, and systems from an overpressure condition.

This rupture disc provides a number of outstanding features:

- Excellent low pressure capabilities
- Non-fragmenting design, when used with non-metallic seals
- 80% operating-to-burst-pressure ratio
- Excellent for gaseous or liquid service
- Three-dimensional flow tag

The Composite Rupture Disc is constructed of two or more components of metallic or non-metallic materials. The rupture disc usually consists of a metallic top section, precision-cut to control the burst pressure, a metallic or non-metallic seal fitted to the concave side of the top section, and an optional vacuum support. It is designed to provide instantaneous, full-opening pressure relief within milliseconds when overpressure occurs.

The 30° angular seat design Composite Rupture Disc is available in sizes ranging from 1" through 12" (25 - 300 mm) and burst ratings as low as 2 psig through 1,440 psig (0,138 - 99,3 barg). Because of the availability of a variety of different seal materials, the Composite Rupture Disc can perform at temperatures up to 1,000°F (538° C) and resist most corrosive and atmospheric conditions. Refer to Table II for recommended maximum operating temperatures of Composite Rupture Disc materials.

The Composite Rupture Disc is recommended for use in systems that have an operating pressure of up to 80% of the rupture disc's rated burst pressure. Under ideal operating conditions, such as static pressure with operating temperatures that are well below the maximum recommended temperatures for the rupture disc material being used, the Composite Rupture Disc may be subjected to operating pressures in excess of 80% of the rated burst pressure. Consult your local representative or the factory for detailed information about the use of the Composite Rupture Disc at operating pressures greater than 80% of the rated burst pressure.

## Corrosion Resistant

The design of the Composite Rupture Disc allows for the use of highly corrosion resistant seal materials, such as Teflon or exotic metallic materials. This is possible because the burst rating of the rupture disc is determined by the slotted metal top section. Therefore, the seal or liner can be made of thin corrosion resistant materials and still provide a wide range of burst pressures – economically. Refer to Table V for minimum/maximum burst pressures for the Composite Rupture Disc.

## Seven-Hole Pattern

LAMOT's Composite Rupture Disc top section is manufactured with a seven-hole pattern at the apex of the rupture disc dome. This seven-hole pattern, along with the six precut sections, provides a non-fragmenting design when used with a non-metallic or Teflon seal.

With the seven-hole pattern, heavier materials of construction can be used. This results in a higher operating to burst pressure ratio – up to 80%.

The use of various seal materials, such as Teflon and exotic metallic materials, provide excellent corrosion resistance. Unlike the metallic seals, non-metallic seals are essential in minimizing fragmentation. *When ordering a Composite Rupture Disc, specify when your application requires the use of a non-fragmenting design rupture disc.*

## Composite Rupture Disc Types

The LAMOT brand includes several types of Composite preformed rupture discs.



The LD is the basic Composite Rupture Disc and consists of a slotted metal top section, with a Teflon or metal seal on the process side of the top section.



The LDV is a type LD Rupture Disc with a vacuum support installed on the process side of the rupture disc.



A type LPL Rupture Disc incorporates a Teflon outlet liner and process side seal for added protection against corrosion or product build up. This rupture disc typically consists of a Teflon outlet liner, metallic top section, and Teflon seal on the process side of the top section.



A LPLV Rupture Disc is like the LPL Rupture Disc, but additionally will withstand full vacuum. It is usually constructed of a Teflon outlet liner, metallic vacuum support, metallic top section, and Teflon seal on the process side of the top section. Positioning Teflon on both the inlet and outlet sides helps protect the vacuum support and top section from corrosive media and reduces product build up.

# STANDARD AND COMPOSITE RUPTURE DISCS

## Manufacturing Range

The manufacturing range is defined as the allowable pressure range within which a rupture disc is rated. It is based upon the customer specified burst pressure. The manufacturing ranges for LAMOT Standard and Composite rupture discs are outlined in Table I.

## Burst Tolerance

After the rupture disc has been manufactured and tested, it is marked with the rated burst pressure. The rated (marked) burst pressure is established by bursting a minimum of two rupture discs and averaging the pressures at which the rupture discs burst. This average is the rated (marked) burst pressure of the rupture disc.

Standard and Composite rupture discs are provided with a burst tolerance as outlined in Table I, in accordance with the ASME Code. Burst tolerance applies only to the rated (marked) burst pressure of the rupture disc.

Table I - Manufacturing Range / Burst Tolerance @ 72°F  
For Standard and Composite Rupture Discs

Specified Burst Pressure		Manufacturing Range		Burst Tolerance
psig	barg	% Under	% Over	
2 - 5	0,138 - 0,345	-40	+40	±25%
6 - 8	0,414 - 0,552	-40	+40	±20%
9 - 12	0,621 - 0,815	-30	+30	±15%
13 - 14	0,896 - 0,965	-10	+20	±10%
15 - 19	1,03 - 1,31	-10	+20	±2 psig (±0,138 barg)
20 - 39	1,38 - 2,69	-4	+14	±2 psig (±0,138 barg)
40 - 50	2,76 - 3,45	-4	+14	±5%
51 - 100	3,52 - 6,90	-4	+10	±5%
101 - 500	6,96 - 34,5	-4	+7	±5%
501 - up	34,6 - UP	-3	+6	±5%

### NOTES:

1. Special reduced manufacturing ranges are available upon request. Please consult your local representative or the factory for additional information.
2. Burst tolerances are the maximum expected variation from the rupture disc's rated (marked) burst pressure.
3. Coincident temperature testing is available upon request.
4. LAMOT brand Standard or Composite rupture discs can be manufactured to comply with ASME Code  Stamp requirements.

## Options

Each rupture disc application has its own unique operating conditions. Factors such as cycling and ratio of operating pressure must be considered to obtain maximum service life. The range of materials available for Standard or Composite rupture discs, combined with optional protective liners, vacuum supports, and protective rings, provide a wide selection of rupture discs for any application.

**Protective Rings** — Protective rings may be used on rupture discs made of thinner materials or in instances where delicate liners are used. These rings protect the rupture disc from foreign material in the seating area. Protective rings also enable easier handling of rupture discs during installation.

**Dent Protectors** — For situations where the outlet (vent side) dome of the rupture disc may require protection from physical environmental elements, an optional dent protector can be supplied to minimize damage.

**Vacuum Supports** — Due to the thinness of some rupture disc materials, it is necessary to support a rupture disc when a system vacuum occurs. Vacuum supports are available that will withstand a full system vacuum, eliminating damage to the rupture disc and ensuring proper operation. For backpressure conditions higher than 14.7 psig (1,01 barg), consult your local representative or the factory. When ordering a Standard or Composite rupture disc that will be subjected to a vacuum condition, clearly specify the exact conditions that the rupture disc will encounter. Vacuum supports will be supplied when specified. Vacuum supports are manufactured to mate with a specific rupture disc and are permanently attached to ensure proper installation.

**Handling Supports** — To aid in the handling of rupture discs that are made of thin materials and help prevent damage during installation, an optional attached Handling Support can be supplied. This helps protect the product from damage that could affect the burst pressure setting of the rupture disc.

**Gaskets** — Gaskets may be used on the process side of the rupture disc to enhance sealing where scratches or pits have occurred in the seating area of the holder. A gasket lines the seating area of the rupture disc, improving sealing capability, provided the holder has been properly cleaned according to product installation instructions.

## Recommended Maximum Temperatures

Normally, the burst pressure of a rupture disc will decrease as the operating temperature increases. Table II states the maximum temperatures for commonly used rupture disc materials, liners, and coatings.

Table II - Maximum Temperature For Rupture Disc Materials, Liners, and Coatings

Materials	Temperature Limit	
	°F	°C
Aluminum	260	127
Nickel / Monel®*	800	427
316SS	900	482
Inconel®*	1,000	538
FEP Teflon Lining or Coating	400	204
TFE or PFA Lining	500	260

## ASME Certification

Continental Disc Corporation has been accredited and is authorized by the ASME Code to utilize the  Code Symbol Stamp for product built in accordance with the requirements of the ASME Boiler and Pressure Vessel Code, Section VIII, Division 1.

The flow performance of LAMOT rupture discs was certified by The National Board of Boiler and Pressure Vessel Inspectors. These certified flow resistance ( $K_R$ ) and minimum net flow area values are available from Continental Disc Corporation or The National Board of Boiler and Pressure Vessel Inspectors.

When specified, LAMOT rupture discs will be manufactured in accordance with ASME Code Sections III or VIII, ISO, DIN, EN, BSI, JIS or other codes as required. The rupture discs will be manufactured, temperature tested and marked to comply with specific code requirements.

## Three-Dimensional Flow Direction Tag

The LAMOT Brand Three Dimensional Flow Direction Tag provides instant visual verification that the rupture disc has been correctly oriented into the system. The 3-D tag extends beyond the holder to insure clear visibility for easier installation and inspection after the rupture disc has been installed.

Tags, as a standard, are attached to all Standard and Composite rupture discs 1" (25 mm) nominal size and above. Tags cannot be attached to a rupture disc intended for use in a Screw Type or Throwing Holder. Tags can be attached, on request, to rupture discs for use in a Union Type Holder. Contact the factory for more details.



## Seating Configurations

The LAMOT Brand Standard Rupture Disc is available in a 30° angular "Light-Lip" seat for normal operating pressures and a 30° angular "Heavy-Lip" seat for higher pressures. Size, burst pressure of the rupture disc and flange class determine the recommended seat design. Refer to Table III for information on application of Heavy-Lip seating.

Table III - Recommended Usage for Heavy-Lip Seating Design

White bar indicates 'psig'. Grey bar indicates 'barg'.

Nominal Size	Flange Class			Rupture Disc Rating (psig / barg)
	ANSI	DIN	JIS	
1/2 in	1500 - UP			6,000 - UP
13mm		320 - UP	-	414 - UP
1 in	1500 - UP			3,600 - UP
25mm		250 - UP	-	248 - UP
1-1/2 in	900 - UP			2,160 - UP
40mm		160 - UP	-	149 - UP
2 in	900 - UP			2,160 - UP
50mm		160 - UP	-	149 - UP
3 in	1500 - UP			3,600 - UP
80mm		250 - UP	-	248 - UP
4 in	1500 - UP			3,600 - UP
100mm		250 - UP	-	248 - UP

NOTE: All other sizes and classes will be provided with "Light-Lip" design.

\* Inconel and Monel are registered trademarks of the Inco family of companies.

# STANDARD AND COMPOSITE RUPTURE DISCS

**Table IV - Minimum/Maximum Burst Pressures for Standard Rupture Discs at 72°F (22°C)**

White bars indicate 'psig'. Grey bars indicate 'barg'.

Rupture Disc Nominal Size	Minimum Burst Pressure at 72°F (22°C)					Standard Rupture Disc Minimum Burst Pressure with Teflon Liner (Add to Rupture Disc Minimum Burst Pressure)		Protective Ring: When Burst Pressure is less than value stated below, a Protective Ring is recommended				
	Aluminum	Monel	Nickel	Inconel	316SS	Inlet or Outlet Only	Both Inlet & Outlet	Aluminum	Monel	Nickel	Inconel	316SS
1/2 in	65	350	300	560	760	150	300	520	3,000	2,290	3,600	3,700
13 mm	4,48	24,1	20,7	38,6	52,4	10,3	20,7	35,9	207	158	248	255
1 in	29	180	150	250	420	50	100	260	1,500	1,145	1,800	1,830
25 mm	2,00	12,4	10,3	17,2	29,0	3,45	6,90	18,0	103	78,9	124	126
1-1/2 in	22	116	100	150	275	35	70	180	1,030	790	1,240	1,255
40 mm	1,52	8,00	6,90	10,3	19,0	2,41	4,83	12,4	71,0	54,4	85,5	86,5
2 in	13	70	60	110	150	25	50	110	635	485	760	775
50 mm	0,896	4,83	4,14	7,58	10,3	1,72	3,45	7,58	43,8	33,4	52,4	53,4
3 in	10	50	45	80	117	15	30	75	445	340	535	545
80 mm	0,690	3,45	3,10	5,52	8,07	1,03	20,7	5,17	30,7	23,4	36,9	37,6
4 in	7	40	35	70	90	11	22	60	350	270	420	430
100 mm	0,483	2,76	2,41	4,83	6,21	0,759	1,52	4,14	24,1	18,6	29,0	29,6
6 in	5	30	25	47	62	8	16	45	260	200	315	320
150 mm	0,345	2,07	1,72	3,24	4,27	0,552	1,10	3,10	17,9	13,8	21,7	22,1
8 in	4	23	20	34	51	6	12	35	200	155	240	245
200 mm	0,276	1,59	1,38	2,34	3,52	0,414	0,827	2,41	13,8	10,7	16,5	16,9
10 in	4	17	16	30	43	5	10	28	160	125	195	200
250 mm	0,276	1,17	1,10	2,07	2,96	0,345	0,690	1,93	11,0	8,62	13,4	13,8
12 in	3	15	13	25	36	4	8	24	135	105	160	165
300 mm	0,207	1,03	0,900	2,14	2,48	0,276	0,552	1,65	9,31	7,24	11,0	11,4

**Table V - Minimum/Maximum Burst Pressures for Prefomed Composite Rupture Discs at 72°F (22°C)**

White bars indicate 'psig'. Grey bars indicate 'barg'.

Rupture Disc Nominal Size	Minimum Pressure for Prefomed Composite Rupture Discs with Teflon Seal							
	LD		LDV		LPL		LPLV	
	TFE	FEP,PFA	TFE	FEP,PFA	TFE	FEP,PFA	TFE	FEP,PFA
1 in	25	30	30	35	35	40	60	80
25 mm	1,73	2,07	2,07	2,42	2,42	2,76	4,14	5,52
1-1/2 in	22	27	25	34	32	38	60	75
40 mm	1,52	1,87	1,73	2,35	2,21	2,63	4,14	5,18
2 in	7	15	10	18	15	20	28	35
50 mm	0,483	1,04	0,690	1,25	1,04	1,38	1,94	2,42
3 in	6	8	8	11	11	16	18	25
80 mm	0,414	0,552	0,552	0,759	0,759	1,11	1,25	1,73
4 in	5	7	7	8	6	9	15	18
100 mm	0,345	0,483	0,483	0,552	0,414	0,621	1,04	1,25
6 in	3	4	5	7	5	7	12	14
150 mm	0,207	0,276	0,345	0,483	0,345	0,483	0,828	0,966
8 in	2	3	5	5	4	5	11	11
200 mm	0,138	0,207	0,345	0,345	0,276	0,345	0,759	0,759
10 in	-	3	-	5	-	5	-	8
250 mm	-	0,207	-	0,345	-	0,345	-	0,552
12 in	-	2	-	4	-	5	-	8
300 mm	-	0,138	-	0,276	-	0,345	-	0,552

# STANDARD AND COMPOSITE RUPTURE DISCS

	Maximum Burst Pressure at 72°F (22°C)					Maximum Burst Pressure at 72°F (22°C) With Teflon Liners					Rupture Disc Nominal Size
	Aluminum	Monel	Nickel	Inconel	316SS	Aluminum	Monel	Nickel	Inconel	316SS	
	1,500	6,000	6,000	6,000	6,000	1,500	6,000	6,000	6,000	6,000	
103	414	414	414	414	103	414	414	414	414	414	13 mm
1,000	6,000	6,000	6,000	6,000	1,000	3,000	3,000	5,000	5,000	5,000	1 in
68,9	414	414	414	414	68,9	207	207	345	345	345	25 mm
750	6,000	6,000	6,000	6,000	700	2,000	2,000	3,400	3,400	3,400	1-1/2 in
51,7	414	414	414	414	48,3	138	138	234	234	234	40 mm
570	4,500	4,000	6,000	6,000	500	1,300	1,300	1,800	1,800	1,800	2 in
39,3	310	276	414	414	34,5	89,6	89,6	124	124	124	50 mm
460	3,200	2,500	4,000	6,000	400	900	900	1,500	1,500	1,500	3 in
31,7	221	172	276	414	27,6	62,1	62,1	103	103	103	80 mm
360	2,400	1,900	3,000	6,000	325	650	650	1,100	1,100	1,100	4 in
24,8	165	131	207	414	22,4	44,8	44,8	75,8	75,8	75,8	100 mm
275	1,800	1,400	2,200	3,600	240	500	500	800	800	800	6 in
19,0	124	96,5	152	248	16,5	34,5	34,5	55,2	55,2	55,2	150 mm
205	1,450	1,100	1,700	2,100	180	375	375	600	600	600	8 in
14,1	100	75,8	117	145	12,4	25,9	25,9	41,4	41,4	41,4	200 mm
165	1,150	800	1,400	1,400	135	300	300	500	500	500	10 in
11,4	79,3	55,2	96,5	96,5	9,31	20,7	20,7	34,5	34,5	34,5	250 mm
140	960	670	1,000	1,000	110	250	250	400	400	400	12 in
9,65	66,2	46,2	68,9	68,9	7,58	17,2	17,2	27,6	27,6	27,6	300 mm

	Minimum Pressure for Preformed Composite Rupture Discs with Metallic Seal For LD, LDV Type Discs					Maximum Pressure for Composite Rupture Discs with:		Rupture Disc Nominal Size
	Aluminum	Nickel	Monel	Inconel	316SS	Teflon Seal	Metallic Seal	
	38	190	230	292	442	500	1,440	
2,63	13,1	15,9	20,2	30,5	34,5	99,3	25 mm	
29	130	150	208	228	500	1,440	1-1/2 in	
2,00	8,97	10,4	14,4	15,8	34,5	99,3	40 mm	
17	78	90	124	208	290	1,100	2 in	
1,18	5,38	6,21	8,55	14,4	20,0	75,8	50 mm	
13	59	65	98	130	160	900	3 in	
0,897	4,07	4,49	6,76	8,97	11,0	62,0	80 mm	
9	46	52	72	98	160	720	4 in	
0,621	3,18	3,59	4,97	6,76	11,0	49,6	100 mm	
7	33	39	56	65	130	640	6 in	
0,483	2,28	2,69	3,87	4,49	8,97	44,1	150 mm	
5	26	30	39	52	110	590	8 in	
0,345	1,80	2,07	2,69	3,59	7,59	40,6	200 mm	
5	21	22	33	46	90	480	10 in	
0,345	1,45	1,52	2,28	3,18	6,21	33,0	250 mm	
4	17	20	29	39	80	400	12 in	
0,276	1,18	1,38	2,00	2,69	5,52	27,5	300 mm	

- NOTES:**
1. Minimum pressures stated are based upon the minimum of the manufacturing range at 72°F (22°C).
  2. For information concerning conditions or a size not shown, consult the factory.

# RUPTURE DISC HOLDERS

The LAMOT brand of rupture disc holders are offered in a variety of types and styles to meet customers' needs. The basic holder is two pieces, consisting of an inlet flange and an outlet flange.

The seating surface of each piece is machined to grip a specific type rupture disc and when assembled together with the rupture disc, forms a gasket seal. Both the 30° seat and flat seat design are machined to industry standards.

The five types of rupture disc holders offered include:

- Insert
- Full Bolted
- Union
- Throwaway
- Screw Type

## Insert Holders

The Insert Holder is a 30° seat holder which fits within the bolting pattern of ANSI, DIN or JIS companion pipe flanges. Insert Holders are furnished with pre-assembly screws and side clips for bench assembly. Installation of the holder is easy, as only half of the companion flange bolts need to be removed entirely in order to remove the assembly for rupture disc replacement.

The Insert Holder is available in nominal sizes ranging from 1/2" through 12" (13 - 300 mm) to mate with ANSI bolting classes 150# through 2500# and corresponding DIN or JIS flanges. Standard materials of construction include carbon steel, 304 or 316 stainless steel. Other materials are available upon request. Refer to Table VI for holder dimensions.



## Tagging

Both full bolted and insert holders are supplied with a permanently attached stainless steel nameplate indicating flow direction. A three dimensional stainless steel flow direction tag is attached to the rupture disc. Directional arrows on the tags and nameplates provide immediate visual verification that the holder and rupture disc assembly have been properly oriented in the system. In addition, whenever specific holder identification tagging is required, a stainless steel Customer Identification Tag is attached for no extra charge.

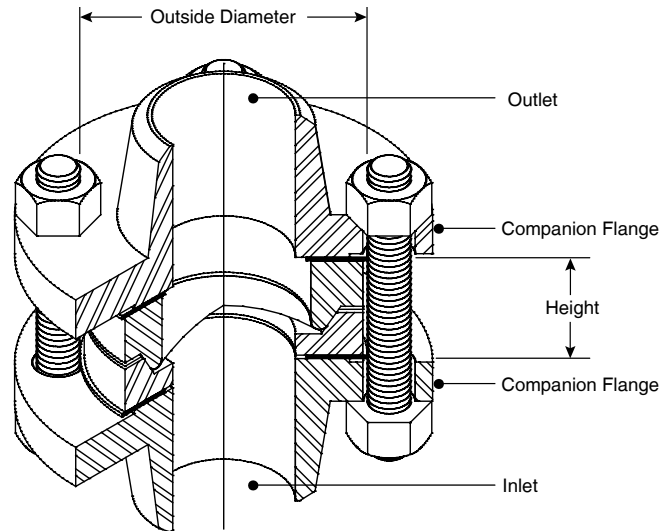



# INSERT RUPTURE DISC HOLDERS

Table VI - 30° Insert Holder Weights and Dimensions

Nominal Size	ANSI		DIN		JIS		Height (in / mm)	Weight (lbs / kg)
	Class	Outside Dia. (in / mm)	Class	Outside Dia. (mm)	Class	Outside Dia. (mm)		
1/2" 13 mm	150	1.75 / 44,5					1.67 / 42	1.0 / 0,45
	300 / 600	2.00 / 50,8					1.67 / 42	1.4 / 0,64
	900 / 1500	2.38 / 60,3					1.86 / 47	2.3 / 1,0
1" 25 mm	150	2.50 / 63,5					1.67 / 42	1.9 / 0,90
	300 / 600	2.75 / 69,9	10 / 40	69,9	10 / 20	69,9	1.67 / 42	2.5 / 1,1
			64 / 160	82,0	30 / 40	76,0	1.67 / 42	2.9 / 1,3
			250	82,0			2.38 / 60	4.9 / 2,2
							2.38 / 60	4.9 / 2,2
1-1/2" 40 mm	900 / 1500	3.00 / 76,2					2.38 / 60	4.1 / 1,9
	150	3.25 / 82,6					1.67 / 42	3.0 / 1,4
	300 / 600	3.63 / 92,2	10 / 40	92,2	10 / 20	86,0	1.67 / 42	3.4 / 1,5
	900 / 1500	3.75 / 95,3					1.67 / 42	4.0 / 1,8
			64 / 160	102,0	30 / 40	97,0	2.66 / 68	6.9 / 2,7
2" 50 mm			250	108,0			1.67 / 42	4.5 / 2,0
	150	4.00 / 101,6			10	101,6	2.66 / 68	8.1 / 3,7
	300 / 600	4.25 / 108,0	10 / 40	108,0	16 / 20	101,6	1.67 / 42	10 / 4,5
			64	111,0			1.67 / 42	3.6 / 1,6
			100 / 160	118,0	30 / 40	111,0	1.67 / 42	4.3 / 2,0
3" 80 mm			250	123,0			1.67 / 42	4.8 / 2,2
	900 / 1500	5.50 / 139,7					3.15 / 80	11 / 5,0
	150	5.25 / 133,4			10	131,0	3.15 / 80	13 / 5,9
	300 / 600	5.75 / 146,1	10 / 40	142,0	16 / 20	137,0	1.67 / 42	17 / 7,8
			16 / 40	142,0			1.67 / 42	5.2 / 2,4
4" 100 mm			64	146,1			1.67 / 42	5.5 / 2,5
	900	6.50 / 165,1	100 / 160	153,0	30 / 40	146,1	1.67 / 42	6.1 / 2,8
	1500	6.75 / 171,5	250	170,0			2.13 / 54	8.9 / 4,0
							2.13 / 54	8.9 / 4,0
							2.13 / 54	10 / 4,5
6" 150 mm							3.21 / 82	19 / 8,6
	150	6.75 / 171,5	10 / 16	162,0	10	156,0	3.21 / 82	23 / 10
	300	7.00 / 177,8	25 / 40	168,0	16 / 20	162,0	3.71 / 94	29 / 13
			64	173,0	30	168,0	3.71 / 94	29 / 13
							1.67 / 42	6.0 / 2,7
8" 200 mm			100 / 160	180,0	40	180,0	1.67 / 42	7.4 / 3,4
	600	7.50 / 190,5	250	202,0			2.15 / 55	12 / 5,4
	900	8.00 / 203,2					1.67 / 42	9.1 / 4,1
	1500	8.13 / 206,5					3.13 / 79	18 / 8,3
							2.15 / 55	13 / 5,9
10" 250 mm							2.15 / 55	14 / 6,4
	150	8.63 / 219,2	10 / 16	217,0	10	217,0	3.63 / 92	26 / 12
	300	9.75 / 247,7	25 / 40	223,0	16 / 20	235,0	3.13 / 79	25 / 11
			64	247,0	30	247,7	4.35 / 111	45 / 20
			100 / 160	257,0	40	262,0	3.63 / 92	37 / 17
12" 300 mm	600	10.38 / 263,7					4.35 / 111	47 / 22
	900	11.25 / 285,8					2.06 / 52	16 / 7,2
							2.06 / 52	17 / 7,7
							2.93 / 74	26 / 12
							2.06 / 52	22 / 9,7
12" 300 mm							3.96 / 101	55 / 25
	150	10.88 / 276,4	10 / 16	272,0	10	267,0	2.93 / 74	37 / 17
	300	12.00 / 304,8	25	283,0	16 / 20	280,0	4.53 / 115	71 / 32
			40	290,0	30	293,0	2.93 / 74	44 / 20
			64	309,0	40	312,0	2.93 / 74	44 / 20
12" 300 mm							3.96 / 101	66 / 30
	150	13.25 / 336,6	10 / 16	327,0	10	330,0	4.53 / 115	95 / 43
	300	14.13 / 358,9	25	340,0	16 / 20	353,0	2.55 / 65	34 / 15
			40	352,0	30	357,0	2.55 / 65	36 / 16
			64	364,0	40	377,0	2.55 / 65	40 / 18
12" 300 mm			100	391,0	16 / 20	353,0	4.18 / 106	69 / 31
	600	15.63 / 397,0			30	357,0	4.18 / 106	81 / 37
							2.55 / 65	49 / 22
							4.18 / 106	86 / 39
							4.18 / 106	88 / 40
12" 300 mm							5.00 / 127	128 / 58
	150	16.00 / 406,4	10	377,0	5	367,0	4.18 / 106	107 / 49
	300	16.50 / 419,1	16	383,0	10	375,0	5.00 / 127	163 / 74
			25	400,0			5.00 / 127	171 / 78
							2.55 / 65	36 / 16
12" 300 mm							2.55 / 65	41 / 19
	150	16.00 / 406,4	40	417,0	16 / 20	403,0	2.55 / 65	42 / 19
	300	16.50 / 419,1	64	424,0	30	417,0	4.13 / 105	46 / 21
							4.13 / 105	94 / 43
							2.55 / 65	60 / 27
12" 300 mm							2.55 / 65	62 / 28
	600	17.88 / 454,2					4.13 / 105	114 / 52
							4.13 / 105	116 / 53
							5.43 / 138	161 / 73
							4.13 / 105	130 / 59
						5.43 / 138	211 / 96	

NOTE: Consult factory for availability of flange classes or sizes not listed.

# FULL BOLTED RUPTURE DISC HOLDERS

## Full Bolted Holders

LAMOT offers nine connection combinations of full bolted holders compatible with ANSI, DIN or JIS bolting classes. Full bolted holders are available in any combination of welded, threaded, or flat faced inlet and outlet connections. These holders are designed to be used with either Standard or Composite 30° seat rupture discs.



The full bolted holder is available in nominal sizes ranging from 1/2" through 12" to mate with ANSI bolting classes 150# through 2500#. Standard materials of construction include carbon steel, 304 or 316 stainless steel. Other materials are available upon request. Refer to Tables VII and VIII for dimensions and connection combinations.

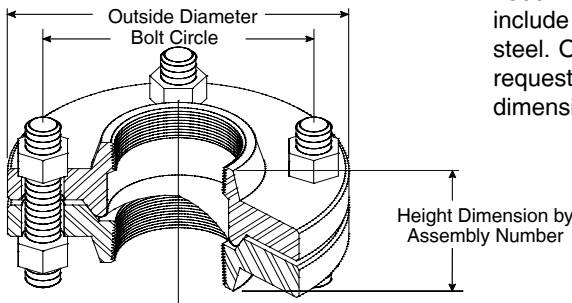

Table VII - Full Bolted Holder Assembly Number and Connections

Assembly Number	Connections	
	Inlet	Outlet
1	Threaded	Flat Face
2	Threaded	Threaded
3	Threaded	Weldneck
4	Weldneck	Flat Face
5	Weldneck	Threaded
6	Weldneck	Weldneck
7	Flat Face	Flat Face
8	Flat Face	Threaded
9	Flat Face	Weldneck

Table VIII - Full Bolted Holder Assembly Dimensions

(All dimensions in inches. See drawing above.)

Nominal Size	ANSI Class	Outside Diameter	Bolt Circle	Studs		Height Dimension Of Full Bolted Assembly Number								
				No.	Diameter	#1	#2	#3	#4	#5	#6	#7	#8	#9
1/2 in	150	3.50	2.38	4	.50	2.20	2.38	3.13	2.81	3.00	3.75	1.75	1.88	2.63
	300	3.75	2.63	4	.50	2.00	2.63	3.50	2.88	3.50	4.38	1.69	1.75	2.63
	600	3.75	2.63	4	.50	2.00	2.63	3.50	2.88	3.50	4.38	1.69	1.75	2.63
	900/1500	4.75	3.25	4	.75	5.56	3.38	4.06	3.38	4.19	4.88	1.88	2.69	3.38
1 in	150	4.25	3.13	4	.50	1.94	2.78	3.56	2.75	3.59	4.38	1.13	1.97	2.75
	300	4.88	3.50	4	.63	2.25	2.97	4.00	3.13	3.84	4.88	1.38	2.09	3.13
	600	4.88	3.50	4	.63	2.38	3.10	4.13	3.25	3.97	5.00	1.50	2.22	3.25
	900/1500	5.88	4.00	4	.88	3.00	3.59	4.75	4.13	4.72	5.88	2.38	2.97	4.13
1-1/2 in	150	5.00	3.88	4	.50	2.25	3.03	4.00	3.13	3.91	4.88	1.38	2.16	3.13
	300	6.13	4.50	4	.75	2.13	2.84	4.00	3.50	4.22	5.38	1.63	2.34	3.50
	600	6.13	4.50	4	.75	2.38	3.09	4.25	3.75	4.47	5.63	1.88	2.59	3.75
	900/1500	7.00	4.88	4	1.00	3.13	3.66	5.13	4.63	5.66	7.13	2.50	3.00	4.50
2 in	150	6.00	4.75	4	.63	2.13	2.97	3.88	3.25	4.10	5.00	1.50	2.35	3.25
	300	6.50	5.00	8	.63	2.44	3.16	4.31	3.63	4.35	5.50	1.75	2.47	3.63
	600	6.50	5.00	8	.63	2.81	3.53	4.69	4.00	4.72	5.88	2.13	2.84	4.00
	900/1500	8.50	6.50	8	.88	3.88	4.63	6.38	5.63	6.38	8.13	3.13	3.88	5.63
3 in	150	7.50	6.00	4	.63	2.56	3.09	4.44	3.75	4.28	5.63	1.88	2.41	3.75
	300	8.25	6.63	8	.75	2.94	3.59	4.94	4.25	4.91	6.25	2.25	2.91	4.25
	600	8.25	6.63	8	.75	3.19	3.85	5.19	4.63	5.28	6.63	2.63	3.28	4.63
	900	9.50	7.50	8	.88	4.00	4.50	6.25	5.75	6.38	8.13	3.00	3.50	5.50
4 in	150	9.00	7.50	8	.63	2.75	3.72	4.88	4.00	4.97	6.13	1.88	2.84	4.00
	300	10.00	7.88	8	.75	3.56	4.34	5.69	4.69	5.47	6.81	2.50	3.28	4.63
	600	10.75	8.50	8	.88	3.88	4.50	5.97	5.63	6.38	7.72	3.13	3.75	5.22
	900	11.50	9.25	8	1.13	5.00	5.38	7.38	6.50	7.13	9.13	3.50	4.50	6.25
6 in	150	11.00	9.50	8	.75	3.25	4.09	5.56	4.75	5.59	7.06	2.19	3.03	4.50
	300	12.50	10.63	12	.75	3.50	4.13	6.50	5.31	5.94	7.88	2.88	3.50	5.06
	600	14.00	11.50	12	1.00	4.75	6.13	7.38	6.75	8.25	9.38	3.63	5.63	4.75
8 in	150	13.50	11.75	8	.75	4.00	5.25	6.88	5.19	6.44	8.06	2.25	3.50	5.13
	300	15.00	13.00	12	.88	4.25	5.38	7.00	6.25	7.25	8.88	3.25	4.75	6.00
10 in	150	16.00	14.25	12	.88	—	—	—	5.25	6.63	8.13	2.38	—	5.25
12 in	150	19.00	17.00	12	.88	2.63	—	4.75	5.75	7.38	7.94	2.50	—	5.69

# UNION TYPE RUPTURE DISC HOLDERS



#2U Holder  
Threaded Inlet - Threaded Outlet



#6U Holder  
Welded Inlet - Welded Outlet

**Also Available:**  
#3U Holder  
Threaded Inlet - Welded Outlet  
#5U Holder  
Welded Inlet - Threaded Outlet

## Union Type Rupture Disc Holders

The Union Type Holder is designed to provide flexibility of use in tight piping configurations. These precisely built holders combine remarkable ease of installation with high pressure ratings in pipe sizes of 2 inches (50 mm) or less. Standard sizes, ratings and bores are shown in Table IX. Contact the factory for applications outside this range.

## Specifications

These holders are designed for Standard or Composite type rupture discs. Any combination of welded or threaded connections is available. All parts are available in Carbon Steel and 316 Stainless Steel. The units are designed with 30° angular seating. A stainless steel tag is welded to the assembly for easy identification of size, pressure rating, and flow direction. Refer to Tables IV and V for rupture disc details.

If the unit has a threaded outlet, it can be supplied with a muffled plug. This reduces reaction forces upon disc rupture, and redirects fragments or product from dispersing directly from the nozzle. For more information on the muffled plug, contact the factory.

The wing nut Union Holder is supplied with extra heavy hammer lugs. This design is a favorite of field personnel who must replace rupture discs in hard to reach locations. The holder can be disassembled easily by hitting the lug with a hammer.

LaMOT wing nut Union Holders are available in 1", 1½", and 2". They have coarse threaded nuts and subs for maximum strength and easy assembly.

The hex nut Union Holders are available in sizes ½", 1", 1½", and 2".

Union Holders are supplied in standard materials of Carbon Steel or Stainless Steel. Other materials are available upon request. Refer to Table VIII for dimensions and maximum holder ratings.



Hammer Union

## Product Identification

As a standard, rupture discs for use in Union Type Holders are shipped with a *detached* tag, which should be affixed to the completed assembly when the rupture disc is installed. Under certain circumstances, the ASME Code will allow such an installation.

For those requiring ASME compliance or simple, positive identification of rupture disc installations, a special Union Type Holder allows the installation of a rupture disc with a permanently attached 3-dimensional flow direction tag. The 3-D flow tag extends beyond the holder for easier verification of orientation after the rupture disc has been installed (not available in 2" 2000# configuration).

When ordering rupture discs, please state whether the disc is to be installed in a Union Type Holder, and whether you require the standard configuration or a permanently attached 3-D flow tag.

Table IX - Union Holder Specifications

Size	Rating	Bore	Hex Size	Overall Height			
				#2U	#3U	#5U	#6U
1/2 in	3000#	Schedule 80	1.75"	2.75"	2.50"	2.55"	2.30"
13 mm			44,5 mm	69,9 mm	63,5 mm	64,8 mm	58,4 mm
1/2 in	6000#	Schedule 160	2.00"	2.81"	2.94"	2.81"	2.94"
13 mm			50,8 mm	71,4 mm	74,7 mm	71,4 mm	74,7 mm
1 in	2000#	Schedule 80	2.50"	3.24"	2.93"	2.93"	2.63"
25 mm			63,5 mm	82,3 mm	74,4 mm	74,4 mm	66,8 mm
1 in	4000#	Schedule 80	3.00"	3.50"	3.03"	3.15"	2.63"
25 mm			76,2 mm	88,9 mm	77,0 mm	80,0 mm	66,8 mm
1 in	6000#	Schedule 160	3.00"	3.50"	3.03"	3.15"	2.63"
25 mm			76,2 mm	88,9 mm	77,0 mm	80,0 mm	66,8 mm
1-1/2 in	2000#	Schedule 80	3.50"	3.75"	3.47"	3.72"	3.50"
40 mm			88,9 mm	95,3 mm	88,1 mm	94,5 mm	88,9 mm
1-1/2 in	4000#	Schedule 80	3.50"	3.75"	3.47"	3.72"	3.50"
40 mm			88,9 mm	95,3 mm	88,1 mm	94,5 mm	88,9 mm
2 in	2000#	Schedule 80	4.25"	3.85"	4.23"	4.35"	4.73"
50 mm			108 mm	97,8 mm	107 mm	110 mm	120 mm
2 in	4000#	Schedule 160	5.00"	5.13"	4.85"	5.10"	5.13"
50 mm			127 mm	130 mm	123 mm	129 mm	130 mm

Table X - Maximum Pressure Ratings for Union Holder

Temp.	3000# Assembly						4000# Assembly				6000# Assembly			
	Carbon Steel*		316SS**		Carbon Steel*		316SS**		Carbon Steel*		316SS**			
	psig	barg	psig	barg	psig	barg	psig	barg	psig	barg	psig	barg		
100	37,8	3000	206	3000	206	4000	275	4000	275	6000	413	6000	413	
200	93,3	2735	188	2580	177	3647	251	3440	237	5470	377	5160	355	
300	149	2660	183	2330	160	3546	244	3107	214	5319	366	4660	321	
400	204	2567	177	2140	147	3423	236	2853	196	5135	354	4280	295	
500	260	—	—	1990	137	—	—	2653	182	—	—	3980	274	
600	316	—	—	1880	129	—	—	2507	172	—	—	3760	259	
700	371	—	—	1810	124	—	—	2413	166	—	—	3620	249	
800	427	—	—	1760	121	—	—	2347	161	—	—	3520	242	
900	482	—	—	1730	119	—	—	2307	159	—	—	3460	238	
1000	538	—	—	1458	100	—	—	1943	134	—	—	2915	201	

\* Carbon Steel ratings are for Group 1.1 from ANSI B16.5  
\*\* 316 SS ratings are for Group 2.2 from ANSI B16.5

Note: A Union Type Holder with extra heavy wing nut lugs is available. Contact the factory for more information.

# SCREW TYPE & THROWAWAY HOLDER ASSEMBLIES

## Screw Type Holder Assembly

The LAMOT Screw Type Assembly is a reusable unit for use in systems with pressures up to 20,000 psig (1,379 barg). A Standard or Composite rupture disc is supplied separately from the Screw Type Holder. After an overpressure condition occurs, changeout is accomplished by disassembling the Screw Type Holder and replacing only the burst rupture disc.

The LAMOT Screw Type Assembly is a flat seat design reusable holder with 1/2" Standard, 11/16" Standard or 11/16" Composite flat seat rupture disc. This assembly is used primarily for laboratory applications and other small pressure vessels or systems.

The Screw Type Holder, used with a Standard or Composite rupture disc, consists of three components:

- inlet
- holddown ring
- outlet

The inlet is available in 1/4", 3/8", and 1/2" male pipe threads (MPT). The outlet is available in 1/2" MPT, muffled or free configurations.

The Screw Type Holder is available with the inlet, outlet, and holddown ring made from brass or 316 Stainless Steel. Specify the required material when ordering. Other materials will be quoted on request.

The Screw Type Holder is reusable. After a rupture disc has burst, it may be replaced by disassembling the outlet from the inlet. The 11/16" rupture disc with its matching holddown ring uses the same inlet and outlet holder as the 1/2" rupture disc with matching holddown ring. Refer to Table XII for Screw Type Holder specifications and dimensions.



Screw Type Assembly

## Screw Type Holder Specifications

Maximum Pressure:	20,000 psig (1,379 barg)
Maximum Temp.:	1,000°F (538°C)
Materials:	All 316 Stainless Steel components

Note: A brass unit is available with a maximum pressure of 1,000 psig (68,9 barg) and a maximum temperature of 400°F (204°C).

## Throwaway Holder Assembly

The Throwaway Assembly is a sealed, disposable unit for use in systems where pressures do not exceed 3,000 psig (207 barg). The assembly features a rupture disc sealed between brass fittings. After relieving an overpressure condition, changeout is easily performed by replacing the entire assembly. The Throwaway Assembly can be supplied with a Standard or Composite rupture disc to accommodate various application requirements.

Throwaway units are used on gas bottles, air conditioning systems, refrigeration units, hydraulic accumulators, gas cylinders, portable compressed air systems and laboratory equipment. The Throwaway unit is a sealed unit.

Two units are available:

- A 1,000 psig (68,9 barg) design is compatible with either a Standard or Composite rupture disc, up to a maximum 1,000 psig burst pressure
- For higher pressures, a 3,000 psig (207 barg) unit is available. It is compatible with a Standard Rupture Disc.

The LAMOT Throwaway unit, with a 1/2" or 3/4" Standard or 11/16" Composite flat seat rupture disc, consists of three brass components:

- inlet
- holddown ring
- outlet

The inlet is available in 1/4", 3/8", 1/2", or 3/4" male pipe threads (MPT). The outlet component is available in various configurations to match the requirement of your application (see Table XIII).

After the rupture disc is installed in the Throwaway Holder, the inlet and outlet components are permanently affixed to provide a *sealed assembly*. Each assembly is then inspected by a Beta Backscanner device to verify compliance to the proper rupture disc material thickness. When an overpressure condition occurs, *the entire assembly can be quickly removed* and replaced with a new assembly.

The maximum temperature limits of the Throwaway Holder are dependent upon the limitations of either the rupture disc or the holder. In the case of the maximum allowable temperature, use the lesser limit of the two.



Throwaway Assembly

## Throwaway Holder Specifications

Maximum Pressure:	1,000 psig or 3,000 psig (68,9 barg) (207 barg)
Maximum Temp.:	400°F (204°C)
Materials:	All brass components

# SCREW TYPE & THROWAWAY HOLDER ASSEMBLIES

## Standard Rupture Discs for Screw Type and Throwaway Holders

Like 30° angular seat Standard Rupture Discs, the 1/2" and 11/16" flat seat Standard Rupture Discs are recommended for operating pressures up to 70% of the rupture disc's rated (marked) burst pressure. The minimum and maximum burst pressures for the 1/2" and 11/16" flat seat Standard Rupture Discs are stated in Table XI.

These rupture discs are available in standard materials of Aluminum, Nickel, Monel, 316SS, or Inconel. Depending on the material of construction, the 1/2" or 11/16" Standard Rupture Disc will perform

at temperatures up to 1,000°F (538°C). Refer to Table II for rupture disc material temperature limits.

The 1/2" and 11/16" Standard Rupture Discs are suitable for liquid or gas processes and static, cyclic, or pulsating service conditions. Options of protective rings or gaskets are available. Option of a vacuum support is available for the 1/2" Standard Rupture Disc. For applications requiring a larger flow area, a Throwaway Holder with 3/4" connections and a 3/4" flat seat rupture disc is available. Burst pressures and dimensions are shown in Tables XI and XIII. Contact the factory for information about operating limitations or options.



1/2" Standard Rupture Disc for Screw Type or Throwaway Holders

## LDV-G Flat Seat Composite Rupture Disc for Screw Type and Throwaway Holders

The 11/16" LDV-G Composite Rupture Disc is a flat seat design consisting of a metal top section, a Teflon seal, metal vacuum support, and CHEMFILM®\* gasket. The 11/16" LDV-G Rupture Disc is available to a maximum burst pressure of 1,000 psig (68,9 barg). The rupture disc may be used in either the Screw Type or Throwaway holders.

This rupture disc offers lower burst pressure capabilities but a higher

operating ratio than the 1/2" or 11/16" Standard Rupture Disc. It is suitable for systems operating up to 80% of the rupture disc's rated (marked) burst pressure and a maximum operating temperature of 400°F (204°C).

The 11/16" LDV-G Rupture Disc is available in standard top section and vacuum support materials of Nickel, Monel, 316SS, or Inconel. It is excellent for use in services handling liquid or gas process and is suitable for static, cyclic, or pulsating operating conditions. Refer to Table XI for minimum/maximum burst pressures of the 11/16" LDV-G series Composite Rupture Disc.



11/16" Composite Rupture Disc for Screw Type or Throwaway Holders

**Table XI - Minimum / Maximum Burst Pressures for Rupture Discs In Screw Type or Throwaway Type Holders**

Subject to holder maximum rating.

Rupture Disc Type	Available Holder Assemblies	Rupture Disc Material	Burst Pressure Minimum / Maximum (72°F / 22°C)			
			Minimum		Maximum	
			psig	barg	psig	barg
11/16" LDV-G with Teflon Seal	Throwaway and Screw Type Assemblies	Nickel	30	2,07	490	33,8
		Monel	30	2,07	615	42,4
		316SS	40	2,76	740	51,0
		Inconel	40	2,76	760	52,4
1/2" Standard 11/16" Standard	Throwaway (to 3,000 psig) and Screw Type Assemblies	Aluminum	65	4,48	1,500	103
		Nickel	300	20,7	6,000	414
		Monel	350	24,1	6,000	414
		316SS	760	52,4	20,000	1379
3/4" Standard	Throwaway Assembly (1,000 psig only)	Inconel	560	38,6	20,000	1379
		Aluminum	47	3,24	1,000	68,9
		Nickel	225	15,5	1,000	68,9
		Monel	265	18,3	1,000	68,9
		316SS	590	40,7	1,000	68,9
		Inconel	405	27,9	1,000	68,9

\*CHEMFILM is a registered trademark of Saint-Gobain Performance Plastics

# SCREW TYPE HOLDER ASSEMBLY

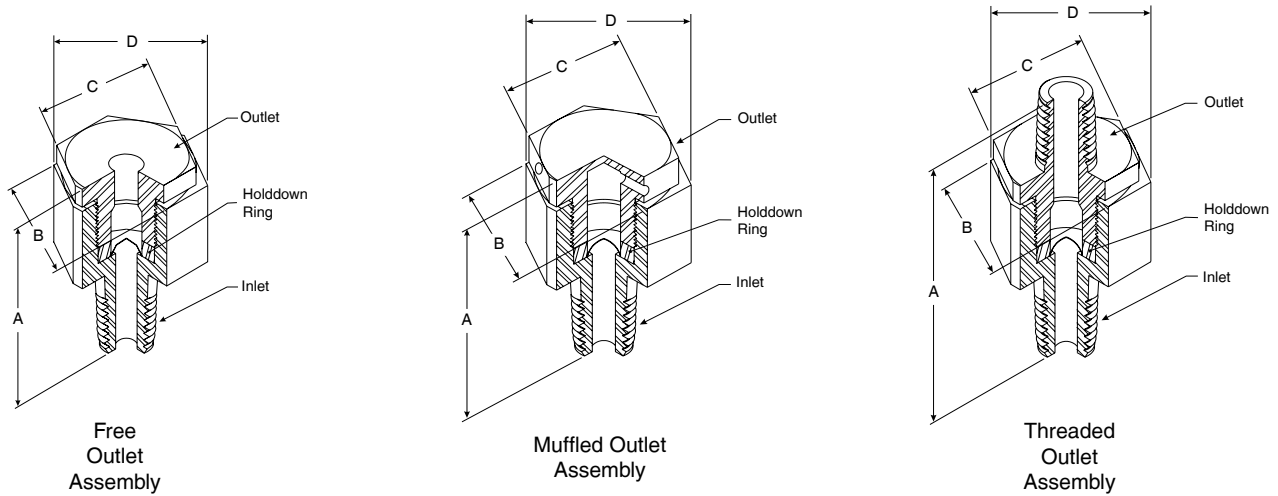
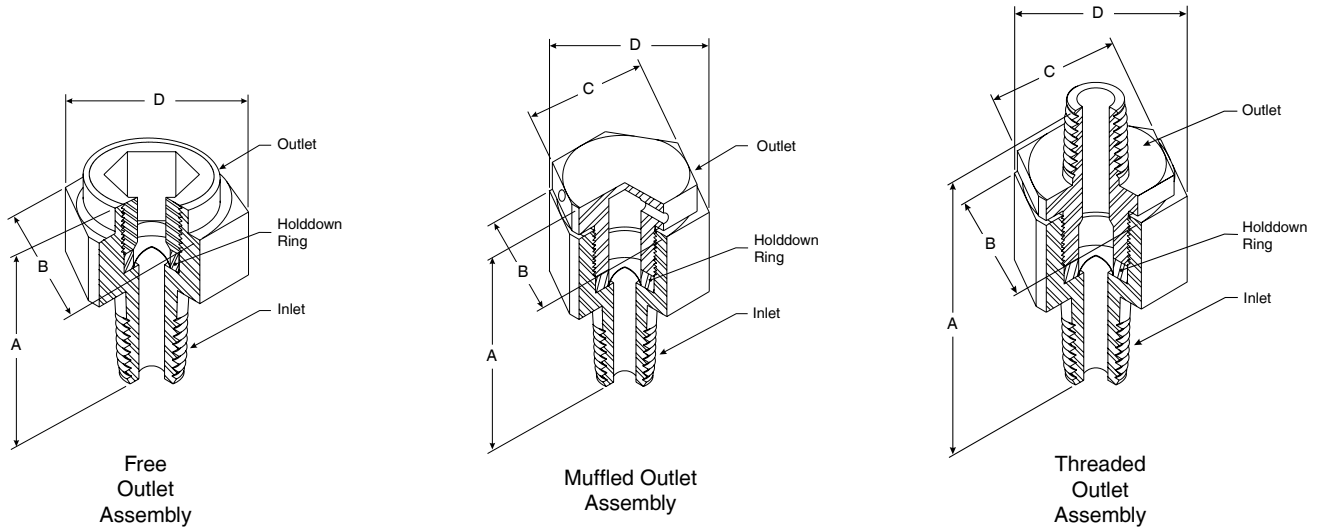

Table XII - Screw Type Holder Specifications and Dimensions

Holder Maximum		Holder Connection		Assembly Number		Rupture Disc Size	Height (A) inch/mm	Dimensions Across Hex Flats		Rotating Diameter Dimension (D)
Pressure @ 72°F / 22°C	Temp.	Inlet	Outlet	Brass	316SS			Inlet (B)	Outlet (C)	
1,000 psig 68,9 barg	400°F 204°C	1/4 MPT	Muffled	BLS1-25-M	—	1 1/16"	2.28 / 57,9	1-1/4 in 31,8 mm	1-1/8 in 28,6 mm	1.44 in 36,6 mm
		3/8 MPT	Muffled	BLS1-37-M	—	1 1/16"	2.28 / 57,9			
		1/2 MPT	Muffled	BLS1-50-M	—	1 1/16"	2.28 / 57,9			
		1/4 MPT	1/2 MPT	BLS1-25-P	—	1 1/16"	2.81 / 71,4			
		3/8 MPT	1/2 MPT	BLS1-37-P	—	1 1/16"	2.81 / 71,4			
		1/2 MPT	1/2 MPT	BLS1-50-P	—	1 1/16"	2.81 / 71,4			
		1/4 MPT	Free	BLS1-25-F	—	1 1/16"	2.03 / 51,6			
		3/8 MPT	Free	BLS1-37-F	—	1 1/16"	2.19 / 55,6			
		1/2 MPT	Free	BLS1-50-F	—	1 1/16"	2.03 / 51,6			
3,000 psig 207 barg	1,000°F 538°C	1/4 MPT	Muffled	—	16LS3-25-M	1 1/16"	2.28 / 57,9	1-1/4 in 31,8 mm	1-1/8 in 28,6 mm	1.44 in 36,6 mm
		3/8 MPT	Muffled	—	16LS3-37-M	1 1/16"	2.28 / 57,9			
		1/2 MPT	Muffled	—	16LS3-50-M	1 1/16"	2.28 / 57,9			
		1/4 MPT	1/2 MPT	—	16LS3-25-P	1 1/16"	2.81 / 71,4			
		3/8 MPT	1/2 MPT	—	16LS3-37-P	1 1/16"	2.81 / 71,4			
		1/2 MPT	1/2 MPT	—	16LS3-50-P	1 1/16"	2.81 / 71,4			
		1/4 MPT	Free	—	16LS3-25-F	1 1/16"	2.03 / 51,6			
		3/8 MPT	Free	—	16LS3-37-F	1 1/16"	2.03 / 51,6			
		1/2 MPT	Free	—	16LS3-50-F	1 1/16"	2.03 / 51,6			
10,000 psig 689 barg	1,000°F 538°C	1/4 MPT	Muffled	—	16LS10-25-M	1/2"	2.28 / 57,9	1-1/4 in 31,8 mm	1-1/8 in 28,6 mm	1.44 in 36,6 mm
		3/8 MPT	Muffled	—	16LS10-37-M	1/2"	2.28 / 57,9			
		1/2 MPT	Muffled	—	16LS10-50-M	1/2"	2.28 / 57,9			
		1/4 MPT	1/2 MPT	—	16LS10-25-P	1/2"	2.81 / 71,4			
		3/8 MPT	1/2 MPT	—	16LS10-37-P	1/2"	2.81 / 71,4			
		1/2 MPT	1/2 MPT	—	16LS10-50-P	1/2"	2.81 / 71,4			
		1/4 MPT	Free	—	16LS10-25-F	1/2"	2.03 / 51,6			
		3/8 MPT	Free	—	16LS10-37-F	1/2"	2.03 / 51,6			
		1/2 MPT	Free	—	16LS10-50-F	1/2"	2.03 / 51,6			
15,000 psig 1,034 barg	1,000°F 538°C	1/4 MPT	1/2 MPT	—	16LS15-25-P	1/2"	2.81 / 71,4	1-1/4 in 31,8 mm	1-1/8 in 28,6 mm	1.44 in 36,6 mm
		1/2 MPT	1/2 MPT	—	16LS15-50-P	1/2"	2.81 / 71,4			
		1/4 MPT	Muffled	—	16LS15-25-M	1/2"	2.34 / 59,4			
		1/2 MPT	Muffled	—	16LS15-50-M	1/2"	2.34 / 59,4			
20,000 psig 1,379 barg	1,000°F 538°C	1/4 MPT	Muffled	—	16LS20-25-M	1/2"	2.97 / 75,4	1-1/4 in 31,8 mm	1-1/8 in 28,6 mm	1.44 in 36,6 mm

# THROWAWAY HOLDER ASSEMBLY



**Table XIII - Throwaway Assembly Specifications and Dimensions for 1/2" or 11/16" Rupture Disc**

Assembly Number		Holder Connections		Unit Weight				Overall Height (A)				Dimension Across Hex Flats				Dimension Across Corners	
												Inlet (B)		Outlet (C)		(D)	
1,000# Assembly	3,000# Assembly	Inlet	Outlet	1,000# Assembly	3,000# Assembly	1,000# Assembly	3,000# Assembly	1,000# Assembly	3,000# Assembly	1,000# Assembly	3,000# Assembly	1,000# Assembly	3,000# Assembly	1,000# Assembly	3,000# Assembly		
				lbs	kgs	lbs	kgs	in	mm	in	mm						
BLT1-25-25	BLT3-25-25	1/4" MPT	1/4" MPT	0.27	0.12	0.32	0.15	2.12	54	2.27	58						
BLT1-25-37	BLT3-25-37	1/4" MPT	3/8" MPT	0.28	0.13	0.33	0.15	2.16	55	2.31	59						
BLT1-25-50	BLT3-25-50	1/4" MPT	1/2" MPT	0.30	0.14	0.35	0.16	2.31	59	2.45	62	1-1/8 in	1-1/4 in	1 in	1 in	1.30 in	1.44 in
BLT1-25-M	BLT3-25-M	1/4" MPT	Muffled	0.25	0.11	0.30	0.14	1.81	46	1.95	50	28,6 mm	31,8 mm	25,4 mm	25,4 mm	33,0 mm	36,6 mm
BLT1-25-F	BLT3-25-F	1/4" MPT	Free	0.20	0.09	0.25	0.11	1.34	34	1.49	38						
BLT1-37-37	BLT3-37-37	3/8" MPT	3/8" MPT	0.29	0.13	0.34	0.15	2.19	56	2.34	59						
BLT1-37-50	BLT3-37-50	3/8" MPT	1/2" MPT	0.31	0.14	0.36	0.16	2.34	60	2.49	63	1-1/8 in	1-1/4 in	1 in	1 in	1.30 in	1.44 in
BLT1-37-M	BLT3-37-M	3/8" MPT	Muffled	0.26	0.12	0.31	0.14	1.84	47	1.99	51	28,6 mm	31,8 mm	25,4 mm	25,4 mm	33,0 mm	36,6 mm
BLT1-37-F	BLT3-37-F	3/8" MPT	Free	0.21	0.10	0.26	0.12	1.37	35	1.53	39						
BLT1-50-50	BLT3-50-50	1/2" MPT	1/2" MPT	0.34	0.15	0.39	0.18	2.50	63	2.50	64	1-1/8 in	1-1/4 in	1 in	1 in	1.30 in	1.44 in
BLT1-50-M	BLT3-50-M	1/2" MPT	Muffled	0.29	0.13	0.34	0.15	2.00	51	2.01	51	28,6 mm	31,8 mm	25,4 mm	25,4 mm	33,0 mm	36,6 mm
BLT1-50-F	BLT3-50-F	1/2" MPT	Free	0.24	0.11	0.29	0.13	1.53	39	1.54	39						

**Table XIII (A) - Throwaway Assembly Specifications and Dimensions for 3/4" Rupture Disc**

Assembly Number	Holder Connections		Unit Weight		Overall Height (A)		Dimension Across Hex Flats		Dimension Across Corners
							Inlet (B)	Outlet (C)	
1,000# Assembly	Inlet	Outlet	lbs	kgs	in	mm			
BLT1-75-75	3/4" MPT	3/4" MPT	0.37	0.17	2.51	63,8	1-1/4 in	1-1/8 in	1.44 in
BLT1-75-M	3/4" MPT	Muffled	0.34	0.15	2.10	53,3	31,8 mm	28,6 mm	36,6 mm
BLT1-75-F	3/4" MPT	Free	0.29	0.13	1.73	43,9			

# LOW PRESSURE ISOLATION SEAL (IS)

## Isolation Seal Rupture Discs

The Isolation Seal (IS) Rupture Disc is a flat, Composite design rupture disc that installs between standard bore, 150# ANSI bolted flanges. This rupture disc is not prebulged but flat, thus the operating pressure is limited to 50% of the rupture disc's minimum burst pressure, in either a positive or negative direction. Flat, non-asbestos gaskets are permanently affixed to the rupture disc's process and vent sides for easy handling and installation.

The "IS" series rupture disc is typically used for:

- Low pressure relief of atmospheric storage tanks
- Downstream relief valve manifold isolation
- As a corrosion barrier
- As an environmental seal

The "IS" Rupture Disc 3-D flow tag is marked with the burst pressure minimum/maximum at a specified temperature. The recommended maximum temperature for an "IS" Rupture Disc with Teflon seal is 400°F (204°C). Standard sizes range from 2" through 12" (50 - 300mm).

As a standard, the "IS" Rupture Disc is manufactured with a top section of 316SS, Inconel, Monel, or Nickel, with a Teflon seal and a non-asbestos gasket on each side of the rupture disc. Polyethylene seals may be used for low pressures.

Two designs are available in the flat "IS" Rupture Disc:

- IS-1 – Bursts in one direction only
- IS-2 – Bursts at an identical rating in either positive or negative direction

For standard minimum/maximum burst pressures, maximum operating pressure, or dimensions, refer to Table XIV and Table XV.

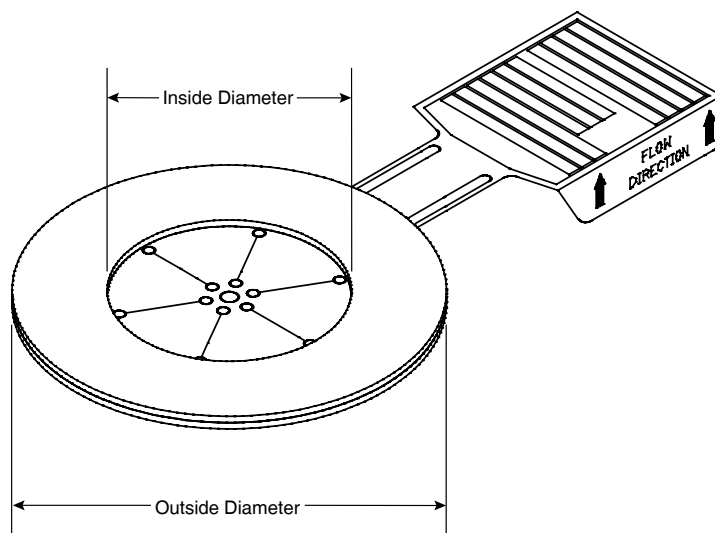

Table XIV - "IS" Rupture Disc Specifications

Nominal Disc Sizes Available		Burst Pressure Min / Max		Max. Operating Pressure	
in	mm	psig	barg	psig	barg
2 - 12	50 - 300	34 - 40	2,34 - 2,76	17	1,17
2 - 12	50 - 300	32 - 38	2,21 - 2,62	16	1,10
2 - 12	50 - 300	50 - 59	3,45 - 4,07	25	1,72
2 - 12	50 - 300	42 - 50	2,90 - 3,45	21	1,45
2 - 12	50 - 300	36 - 43	2,48 - 2,96	18	1,24
2 - 12	50 - 300	30 - 36	2,07 - 2,48	15	1,03
2 - 12	50 - 300	24 - 30	1,65 - 2,07	12	0,827
2 - 12	50 - 300	20 - 25	1,38 - 1,72	10	0,689
2 - 12	50 - 300	16 - 21	1,10 - 1,45	8.0	0,552
2 - 12	50 - 300	14 - 18	0,965 - 1,24	7.0	0,483
2 - 12	50 - 300	12 - 15	0,827 - 1,03	6.0	0,414
2 - 12	50 - 300	11 - 14	0,758 - 0,965	5.5	0,379
2 - 12	50 - 300	10 - 13	0,689 - 0,896	5.0	0,345
2 - 12	50 - 300	9.0 - 12	0,621 - 0,827	4.5	0,310
2 - 12	50 - 300	8.0 - 11	0,552 - 0,758	4.0	0,276
2 - 12	50 - 300	7.0 - 10	0,483 - 0,689	3.5	0,241
2 - 12	50 - 300	6.0 - 9.0	0,414 - 0,621	3.0	0,207
3 - 12	80 - 300	5.0 - 8.0	0,345 - 0,552	2.5	0,172
3 - 12	80 - 300	4.0 - 7.0	0,276 - 0,483	2.0	0,138
4 - 12	100 - 300	3.0 - 5.0	0,207 - 0,345	1.5	0,103
6 - 12	150 - 300	2.0 - 4.0	0,138 - 0,276	1.0	0,069
8 - 12	200 - 300	1.6 - 3.6	0,110 - 0,248	0.8	0,055
10 - 12	250 - 300	1.2 - 3.2	0,083 - 0,221	0.6	0,041
12	300	1.0 - 3.0	0,069 - 0,207	0.5	0,034

\* The rupture disc's manufacturing range and burst tolerance are included in the burst pressure min/max stated above.

Table XV - "IS" Rupture Disc Dimensions for 150# ANSI Bolted Flanges

Nominal Size	Inside Diameter	Outside Diameter
2"	2.38	4.13
50mm	60.5	104.9
2-1/2"	2.88	4.88
65mm	73.2	124.0
3"	3.50	5.38
80mm	88.9	136.7
3-1/2"	4.00	6.38
90mm	101.6	162.1
4"	4.50	6.88
100mm	114.3	174.8
6"	6.63	8.75
150mm	168.4	222.3
8"	8.63	11.00
200mm	219.2	279.4
10"	10.75	13.38
250mm	273.1	339.9
12"	12.75	16.13
300mm	323.9	409.7



# B.D.I.<sup>®</sup> (BURST DISC INDICATOR) ALARM SYSTEM

The state-of-the-art **B.D.I. Alarm System** is designed specifically for use with LaMOT Standard and Composite rupture discs.

The B.D.I. Alarm System consists of an alarm strip, interfaced with a monitoring unit, computer, annunciator panel, control panel, or other equipment. The alarm system is activated by the opening of a rupture disc.

The B.D.I. Alarm System is a normally closed, low-powered circuit. When a rupture disc opens, the alarm strip is severed, interrupting the circuit which activates a monitoring device, sold separately. This device is used to signal that an overpressure condition has occurred and that media is venting.

The heart of the alarm system is the B.D.I. Alarm Strip. Composed of copper conductors adhered to a layer of Teflon film, the strip is sandwiched between non-asbestos or Teflon gaskets. The tail of the strip extends from the gasket seating area and joins with a B.D.I. Connector, completely protected with polyolefin heat shrink tubing.

## Proven features include:

- Signals instantly when a rupture disc has opened
- Positive signal of fugitive emissions and/or the occurrence of an overpressure relief condition
- Signals emergency equipment, control room, and/or operating personnel to alter or stop a process
- Prevents an undetected open vent line once an overpressure condition occurs

## SPECIFICATIONS:

### The B.D.I. Alarm System may be used on the following LaMOT products:

- Standard Rupture Disc
- Composite Rupture Disc

### The B.D.I. Alarm System may not be used in the following LaMOT holders:

- Union
- Screw Type
- Throwaway
- Full Bolted

## B.D.I. Alarm Strip operating limits:

- Maximum current: 50 milliamps
- Maximum voltage: 24 VDC RMS
- Temperature: -40°F to 400°F  
(-40°C to 206°C)

## Monitor operating limits:

- Power Source:
  - 115/230VAC @ 50/60 Hz or
  - 24 or 12 VDC ±1 volt
- Output relay contacts rating:
  - 2 AMPS @ 120 V resistive
  - 1 AMP @ 120 V inductive
  - 2 AMPS @ 24 V inductive
- Operating temperature range:
  - To 122°F (50°C)

## Construction:

- The standard monitor unit has a NEMA 1 wall mounted enclosure
- Enclosures are available for other NEMA classifications
- Monitors specifically designed to meet special requirements are available
- MTB-700 utilizes FM Approved Barrier



# HOW TO ORDER

Specific information is necessary when ordering a rupture disc product. To facilitate manufacturing and assure selection of the correct rupture disc and holder for your application, please determine:

## LAMOT RUPTURE DISCS:

Type \_\_\_\_\_  
Quantity \_\_\_\_\_  
Size \_\_\_\_\_  
Rupture disc material \_\_\_\_\_  
Burst pressure \_\_\_\_\_  
Temperature \_\_\_\_\_ °F / °C  
Manufacturing range \_\_\_\_\_  
Vacuum support  yes  no  
Vacuum support material \_\_\_\_\_  
Special liners or coatings \_\_\_\_\_  
Gasket material \_\_\_\_\_  
Previous manufacturing number (if known) \_\_\_\_\_  
B.D.I. Alarm System  yes  no  
Non-fragmenting design required  yes  no  
(For rupture discs in Union Holders)  
Rupture Disc Tag Should Be:  Attached  Detached

## OPERATING SPECIFICATIONS:

M.A.W.P. \_\_\_\_\_  
Operating pressure \_\_\_\_\_  
Operating temperature \_\_\_\_\_  
Vacuum / backpressure conditions \_\_\_\_\_  
Cycle conditions \_\_\_\_\_  
Flow rate required \_\_\_\_\_  
Process media \_\_\_\_\_  
Molecular weight / specific gravity \_\_\_\_\_  
Installed in connection with PRV  yes  no  
(Non-fragmenting design required)

## LAMOT RUPTURE DISC HOLDERS:

Type \_\_\_\_\_  
(If Union Type, please state whether the rupture disc tag should be attached or detached. See page 11.)  
Quantity \_\_\_\_\_  
Nominal size \_\_\_\_\_  
Inlet material \_\_\_\_\_  
Outlet material \_\_\_\_\_  
Connection type \_\_\_\_\_ inlet \_\_\_\_\_ outlet  
Bolting class \_\_\_\_\_  
Special coating \_\_\_\_\_

## LAMOT RUPTURE DISC HOLDER OPTIONS / ACCESSORIES:

Jack screws  yes  no  
Gauge tap  yes  no  
Pressure gauge \_\_\_\_\_  
Excess flow valve  yes  no  
J-Hook  yes  no

## QUALITY ASSURANCE / DOCUMENTATION:

ASME Code tests (  Stamp) \_\_\_\_\_  
Special cleaning / packaging \_\_\_\_\_  
Special tagging \_\_\_\_\_  
Material test reports \_\_\_\_\_  
Burst test report \_\_\_\_\_

For technical assistance and/or sales:

Phone: (816) 792-1500  
FAX: 816) 792-2277 / 5447

# LAMOT®

## An Industry Leader

Continental Disc Corporation is the innovative leader in rupture disc technology. **QUALITY, TECHNICAL SUPPORT and INNOVATIVE PRODUCTS** are the benchmarks that enable us to provide you, our customers, with the best possible products and services. Our rupture discs complement the LAMOT product line, thus providing a complete line of rupture discs from which our customers can choose.

### QUALITY

We believe quality starts with our first contact with you and continues even after you receive our product.

### SERVICE

We are committed to providing technical assistance, training, fast understandable quotations, and recommending the right product to fit the application.

### TECHNICAL SUPPORT

Our policy is to continuously train in-house and field personnel. This has resulted in Continental Disc Corporation's reputation as a provider of:

**CORRECT, EFFECTIVE ANSWERS**  
to  
**SPECIAL PRESSURE RELIEF**  
**APPLICATION PROBLEMS.**

Continental Disc Corporation has a worldwide representative network. Contact any of our offices listed on the back of this brochure for the name of the authorized representative in your area.

For further information about Continental Disc Corporation products, contact any of our offices listed on the back page.



## CONTINENTAL RUPTURE DISCS

Continental Disc Corporation manufactures a wide range of overpressure and vacuum relief devices that protect vessels, equipment, and systems from damaging overpressure conditions. Some of these include:

### • HPX™ RUPTURE DISC

The HPX rupture disc is a scored reverse acting rupture disc. This differential pressure relief device features an instantaneous full-open relief area for protecting equipment, vessels, systems and people from an overpressure condition. This high precision reverse acting rupture disc offers proven performance in excess of 250,000 cycles at a 95% operating ratio.



### • ULTRX® RUPTURE DISC

Scored, reverse acting rupture disc without knife blades for both GASEOUS and LIQUID systems, and operating pressures to 90%.



### • STAR X®/LOTRX® RUPTURE DISC

STAR X and LOTRX are part of Continental's unique scored, reverse acting rupture disc line. STAR X is ideal for primary and/or secondary system relief protection, or when used to isolate a safety relief valve, provides an effective means of fugitive emission control. LOTRX is ideal for low pressure applications and gas service.

### • SANITRX HPX™ RUPTURE DISC

The SANITRX HPX rupture disc is a scored reverse acting rupture disc designed specifically for the pharmaceutical, food and beverage, and biotech industries. This differential pressure relief device features an instantaneous full-open relief area for protecting equipment, vessels, systems and people from an overpressure condition. This high precision reverse acting rupture disc offers proven performance in excess of 250,000 cycles at a 95% operating ratio.



### • CAL-VAC®/POS-A-SET® ASSEMBLIES

Ultra-low pressure rupture disc for burst pressures as low as 1 inch water column, vacuum or positive.

### • CLEAN-SWEEP® ASSEMBLY

A rupture disc assembly specifically designed for viscous media applications which places the rupture disc next to the process flow.

### • SANITARY FITTING ASSEMBLY

A holder designed with sanitary clamp connections for easy, quick installation and removal from the system.

### • VENT PANELS

In square, rectangular or circular configuration, the vent panel provides instantaneous opening, thus minimizing structural or mechanical damage caused by expanding gases.

### • QUICK-CHANGE® HOLDER

A permanently mounted holder with rupture disc cartridge allows for fast rupture disc changeout without having to remove a pressure relief valve or outlet piping. Especially good for tight or difficult-to-reach installations.



Continental Disc Corporation has representatives located throughout the world.  
Contact the office nearest you for the authorized representative in your area.

### CORPORATE HEADQUARTERS

Continental Disc Corporation  
3160 W. Heartland Drive  
Liberty, MO 64068-3385 USA

Phone: (816) 792-1500  
FAX: (816) 792-2277/5447  
E-mail: [pressure@contdisc.com](mailto:pressure@contdisc.com)  
Website: [www.contdisc.com](http://www.contdisc.com)

### THE NETHERLANDS

Continental Disc Corporation  
Energieweg 20  
2382 NJ Zoeterwoude-Rijndijk  
The Netherlands

Phone: + (31) 71-5412221  
FAX: + (31) 71-5414361  
E-mail: [cdcnl@contdisc.com](mailto:cdcnl@contdisc.com)

### CHINA

Continental Disc Corporation  
Room 910, Tower B, COFCO Plaza  
No. 8 JianGuoMenNei Avenue  
Beijing (100005), P.R. China

Phone: + (86) 10-6522-4885  
Fax: + (86) 10-6522-2885  
Mobile: + (86) 137-0103-8871  
E-mail: [cdcchina@contdisc.com](mailto:cdcchina@contdisc.com)

### INDIA

Groth Continental Mfg. Pvt. Ltd.  
Survey No. 423/P, Mahagujarat  
Industrial Estate, Moraiya, Sarkhej-  
Bavla Road, Ahmedabad 382213,  
INDIA

E-mail: [gcmpl@contdisc.com](mailto:gcmpl@contdisc.com)

Represented by:

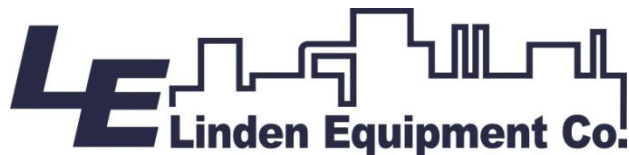

**1185 Tower Road  
Schaumburg, IL 60173  
Ph: 847.885.0300 Fax: 847.885.0303  
[lindenequipment.com](http://lindenequipment.com)**



China Manufacture License  
Available When Specified