

PILOT OPERATED RELIEF VALVE
SERIES 1660A



Model 1660A
U.S. Patent No. 5,499,648

Model 1401E
U.S. Patent No. 5,163,471

Model 1402
U.S. Patent No. 5,992,449

- Premium seat tightness to set pressure
- Snap or modulating valve action
- Provides ability to meet “Clean Air Act” requirements

Typical Tank Installation

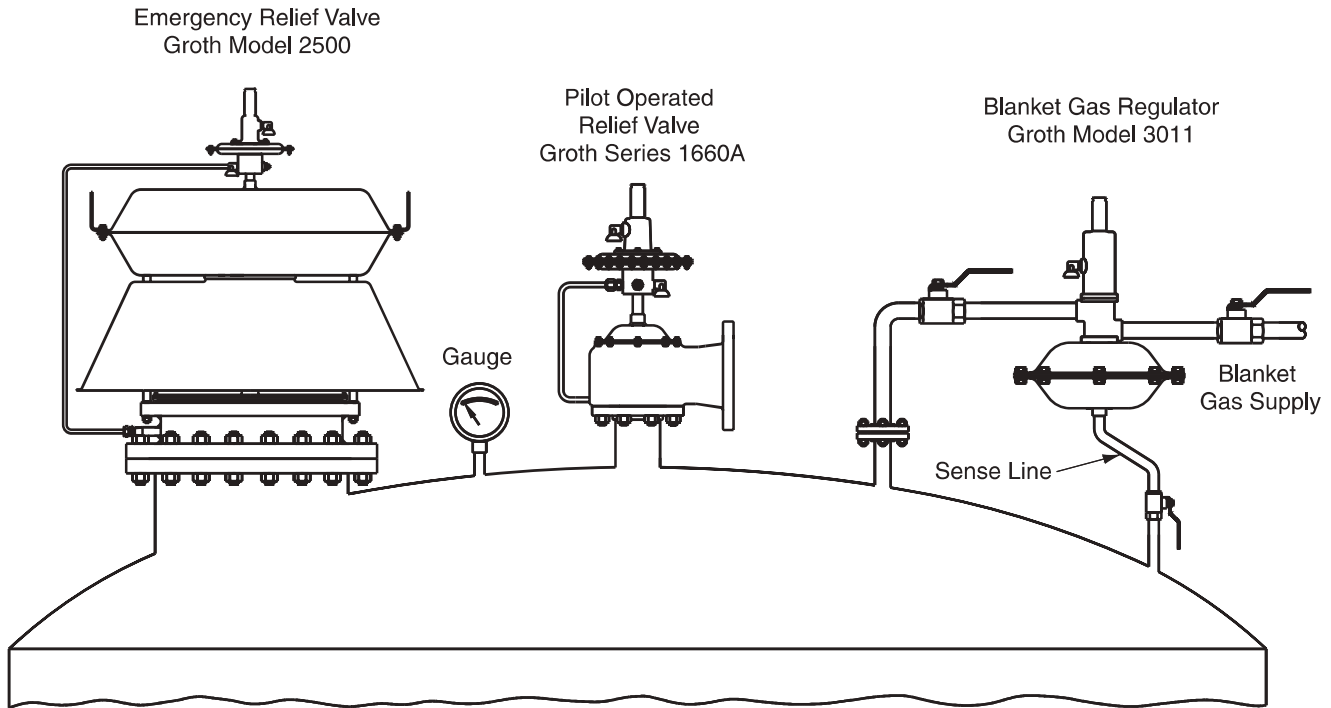

Figure 1

Pressure and/or vacuum relief valves are used on liquid storage tanks and other process vessels or systems to prevent structural damage due to excess internal pressure or vacuum.

Storage tanks are pressurized when liquid is pumped in and compresses the existing vapor or when increasing temperature causes increased evaporation or expansion of existing vapor. Conversely, vacuum may be created when pumping out or decreasing temperature. To prevent damage, vapor must be allowed to escape or enter the tank at a specified pressure or vacuum. The volume rate of venting depends upon the tank size, volatility of the contents, the pumping rate and the temperature. See API Standard 2000 for the procedures to determine venting requirements.

The pilot operated relief valve has two principal advantages over other types of relief valves:

- 1) It is bubble tight to set pressure.
- 2) It is fully open at less than 10% above set pressure.

These characteristics permit an operating pressure nearer to the maximum allowable working pressure of the tank. High operating pressures reduce evaporation and total venting volume, thereby reducing product loss and cost of processing emissions.

A tank may also have provisions for emergency pressure relief due to fire exposure and/or an inert gas blanket in the vapor space.

A typical tank installation is shown in Figure 1 which includes a pilot operated pressure/vacuum relief valve, a gas blanketing regulator and a pilot operated emergency pressure relief valve.

The Groth Series 1660A Pilot Operated Valve is available in the following configurations:

	RELIEF SERVICE	
	PRESSURE	VACUUM
1660A	✓	
1661A	✓	✓ DIRECT ACTUATED
1662A		✓ PILOT OPERATED
1663A	✓	✓ PILOT OPERATED

See pages 603, 604 and 611.

FEATURES

- Sizes 2" through 12"
- Full Pipe Bore Seat Nozzle
- Standard Pressure Settings from 2.0" W.C. to 15 PSIG
- Temperature Range from -323° F to 300° F
- Designed for Easy Maintenance
- Minimal Spare Parts Requirements
- Inherent Backflow Prevention
- ISO 9001 Certified Manufacturing Process
- Easily Adjustable Blowdown
- Snap Action or Modulating Pilot
- Premium Seat Tightness to Set Pressure.
- Standard Body Materials are Aluminum, Carbon Steel, or 316 S.S.
- Film seat design meets EPA Method 21

APPLICATIONS

LOW PRESSURE STORAGE TANKS

The Groth Model 1660A Pilot Operated Valves can meet seat tightness requirements of environmental regulations, even when the operating pressure is close to the set pressure, such as when gas blanketing is used.

CRYOGENIC STORAGE TANKS

Leaking pressure relief valves on low temperature tanks cause unsafe freeze-ups. Tight pilot operated valves with snap action are the safest devices known. Modulating valves must not be used on cryogenic service.

NATURAL GAS

Some natural gas production facilities require large volume relief capacities at low pressures and pilot operated valves are ideal for these applications. When the relief valve is installed downstream of a pressure reducing valve, the modulating mode can prevent destructive interaction between the two valves.

AIR SEPARATION PLANTS

Pilot operated valves prevent the accidental loss of gases when used in both low pressure process and storage applications.

AIR BLOWERS

Air blowers for conveyor systems and waste water treatment plants, as well as other uses, often require accurate relief for both pressure and vacuum. Pilot operated relief valves—both pressure valves and vacuum valves—are extremely well suited for such services.



DESIGN AND FUNCTION

Model 1660A - Pressure Relief - Pilot Actuated

The function of the pilot valve (A) is to control pressure in the main valve actuator (B) or upper dome of the main valve. The effective area of the actuator diaphragm (1) is significantly larger than the pallet seat area (2). Tank pressure is applied both on top of the actuator diaphragm and below the main valve seat area. **Because of the area ratio, the downward force is greater than the opening force and results in a tight main valve seat.**

When tank pressure reaches set pressure, the force acting upward on the pilot valve sense diaphragm overcomes the downward spring force. The pilot valve begins to flow through the seat (6) to the breather port (3). This flow results in a pressure drop in the upper dome (B). **As a result, pressure acting under the main valve pallet will open the valve and relieve the over-pressure condition.**

Adjustment of the blowdown needle (4) can provide either **“snap action”** or **“modulating” pilot valve operation**. For snap-action operation, the main valve pallet lifts quickly to full open. In modulating service, the pallet will lift sufficiently to maintain set pressure regardless of the flow rate up to the rated capacity of the valve at the specified set pressure.

The main valve remains open (and flowing) as long as the tank pressure is higher than the pilot valve set pressure.

As tank pressure decreases to the pilot valve reseal pressure, the pilot valve closes allowing tank vapors to flow back into the upper dome (B). As the upper dome pressure rises, the pallet assembly is tightly closed against the seat.

The adjustable orifice or blowdown needle (4) affects the closing of the pilot valve. Blowdown can vary from zero for modulating operation to 10% for snap-action operation.

NOTE: The actuator diaphragm (1) is not attached to the support plate (5) unless vacuum relief or Low set 1402 pilot is specified. This design provides **“inherent back-flow prevention”** when the discharge header pressure exceeds tank pressure. No additional hardware is required for this protection.

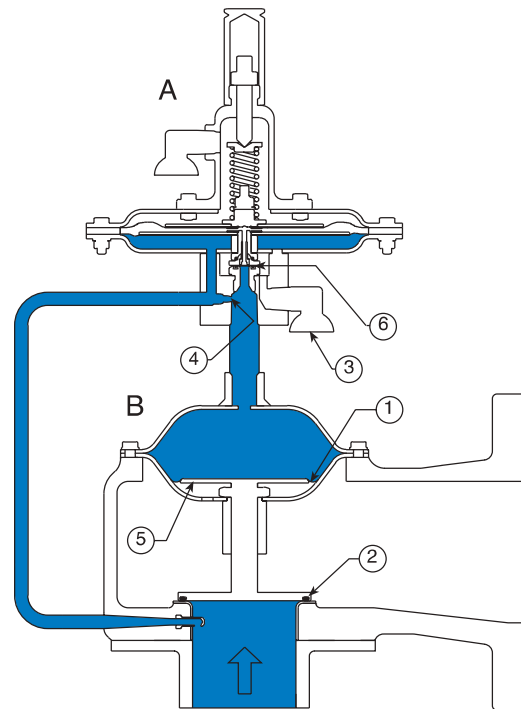

Closed Condition

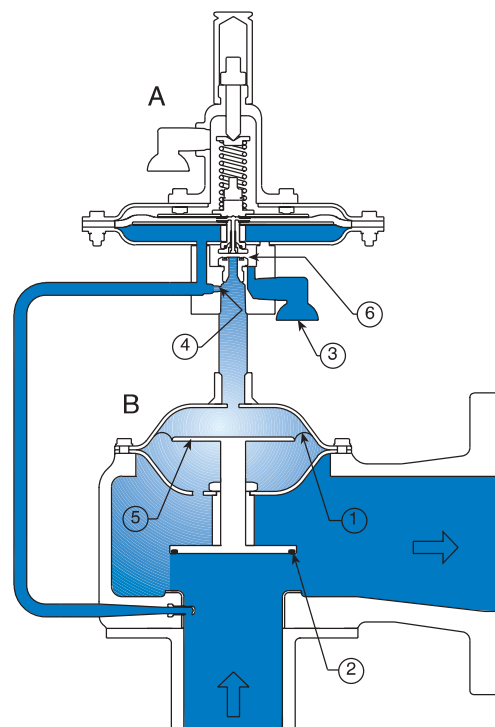

Open Condition

DESIGN AND FUNCTION

Model 1661A - Pressure Relief - Pilot Actuated Vacuum Relief - Direct Actuated

Vacuum relief is provided by attachment of the actuator diaphragm to the pallet/support plate assembly. This provides pressure and vacuum protection with a single main valve and a single pilot valve.

The valve opens when the tank vacuum acting on the actuator diaphragm overcomes the weight of the pallet assembly. The vacuum applied to the area differential between the actuator diaphragm (1) and the pallet seat area (2) provides the lifting force. The vacuum cracking pressure is approximately 1.0 - 2.0" WC, and is determined by the weight of the pallet assembly and related components. Full open flow is achieved in the 1.7" to 3.5" WC range, depending on valve size, pressure setting and materials of construction. The diaphragm is attached by the upper support plate (8), so backflow prevention is not provided by this valve.

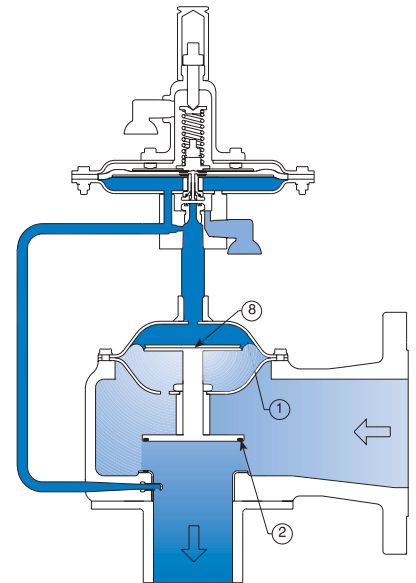

Open Condition—Direct Actuated

Model 1662A - Vacuum Relief - Pilot Valve Actuated

Operation of a Pilot Actuated Vacuum Relief Valve is similar to pressure relief except for the physical connections between the pilot and main valve. The vacuum sense lines (9 & 10) connect the spring chamber breather port and the pilot valve exhaust port to the main valve total pressure pick-up as shown.

Atmospheric pressure is applied under the boost and sense diaphragms and in the upper dome (B) through the breather port (3). Below set vacuum the spring force is greater than the lift created by tank vacuum above the sense diaphragm (7) so both the pilot valve and the main valve will remain closed.

At set vacuum the pilot valve opens and the upper dome is reduced to tank vacuum. The diaphragm is attached by a second actuator support plate (8) for vacuum operated valves. Main valve internal pressure under the actuator diaphragm (1) opens the main valve. The valve remains open and flowing until the system reaches the pilot valve reseal pressure.

NOTE: Backflow pressure relief prevention is provided for pilot operated vacuum relief valves in case positive system pressure can occur. A bypass line with a check valve is used to apply pressure to the upper dome. Another check valve prevents pressure discharge from the pilot vent.

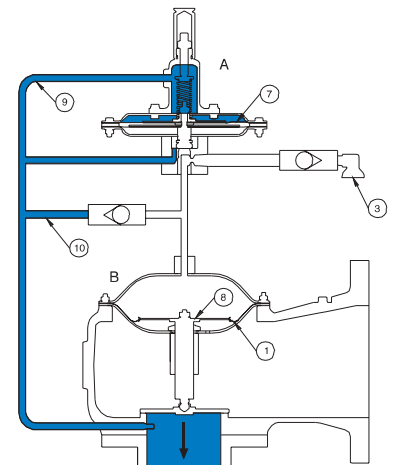

Closed Condition

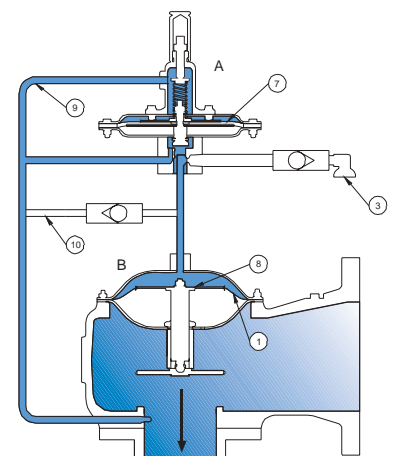

Open Condition

CAUTION:

See Technical Section TPD3 for Modes of Failure.

Model 1660A Pilot Operated Relief Valve

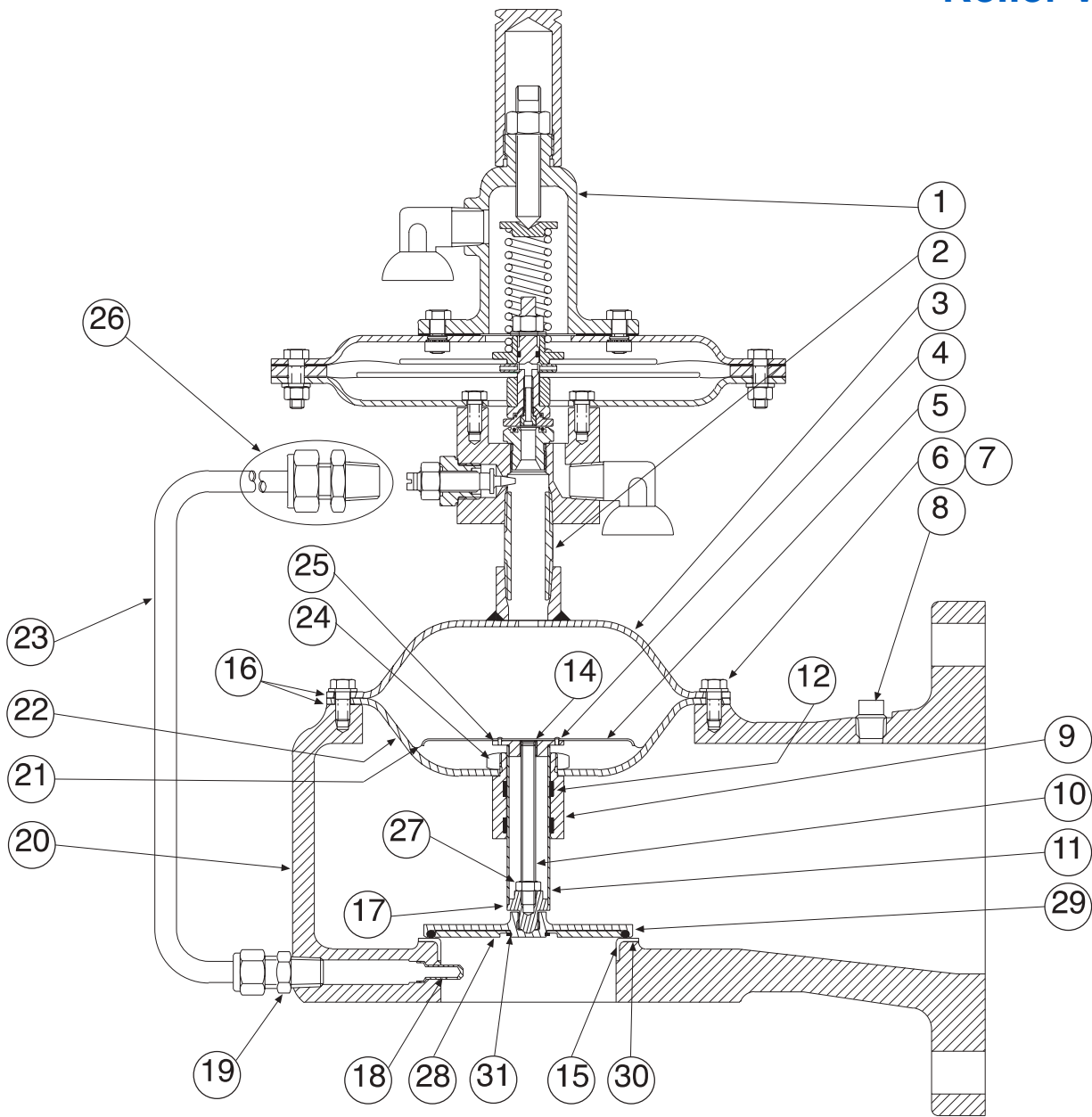

NOTE:
Pilot Valve is rotated 90° to show
blowdown needle and exhaust port;
see section A-A on pg. 607.

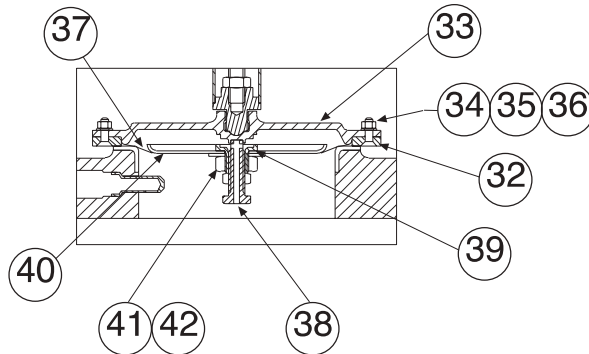

Film Seat Detail

U.S. PATENT NO. 5,499,648

Model 1660 Pilot Operated Relief Valve

Item	Description	Materials of Construction		
		Aluminum	Carbon Steel	Stainless Steel
1	Pilot	SS	SS	SS
2	Nipple, Pipe	316 SS	316 SS	316 SS
3	Housing, Upper Actuator	AL	CS	316 SS
4	Rivet	SS	SS	SS
5	Plate, Diaphragm	AL	316 SS	316 SS
6	Bolt, Hex	316 SS	316 SS	316 SS
7	Washer, Lock	316 SS	316 SS	316 SS
8	Plug, Pipe	316 SS	316 SS	316 SS
9	Guide, Spindle	AL	316 SS	316 SS
10	Rod, Spindle	316 SS	316 SS	316 SS
11	Spindle	316 SS	316 SS	316 SS
12	Bearing, Spindle	PTFE	PTFE	PTFE
13	Stud/Nut (not shown)	316 SS	316 SS	316 SS
14	Insert, Locking	316 SS	316 SS	316 SS
15	Seat, Body	See Note 3	316 SS	See Note 3
16	Gasket, Actuator	Teflon® FEP ⁴	Teflon® FEP ⁴	Teflon® FEP ⁴
17	Cap Spindle, Lower	AL	316 SS	316 SS
18	Pickup, Pressure	316 SS	316 SS	316 SS
19	Tube Connector	316 SS	316 SS	316 SS
20	Body	AL	CS	CF8M (316 SS)
21	Diaphragm, Actuator	Teflon® FEP ⁴	Teflon® FEP ⁴	Teflon® FEP ⁴
22	Housing, Lower Actuator	AL	CS	316 SS
23	Tubing	316 SS	316 SS	316 SS
24	Nut, Hex Jam	316 SS	316 SS	316 SS
25	Cap, Spindle-Upper	AL	316 SS	316 SS
26	Connector, Tube	316 SS	316 SS	316 SS
27	Nut, Hex Jam	316 SS	316 SS	316 SS
28	Retainer Plate, O-Ring	AL	316 SS	316SS
29	Pallet, O-Ring	AL	316 SS	316 SS
30	O-Ring	See Note 1	See Note 1	See Note 1
31	Retainer, Snap Ring	SS	SS	SS

FILM SEAT COMPONENTS (ITEMS 1-27 ARE SAME AS ABOVE)

32	Ring, Film Seat	AL	316 SS	316 SS
33	Plate, Film Seat	AL	316 SS	316 SS
34	Screw, Hex Skt Flt Hd	SS	SS	SS
35	Nut, Hex	SS	SS	SS
36	Washer, Lock	SS	SS	SS
37	Seat, Film	Teflon® FEP ⁴	Teflon® FEP ⁴	Teflon® FEP ⁴
38	Jackscrew	316 SS	316 SS	316 SS
39	Bushing, Jackscrew	316 SS	316 SS	316 SS
40	Retainer, Film Seat	AL	316 SS	316 SS
41	Nut, Hex Jam	316 SS	316 SS	316 SS
42	Washer, Flat	316 SS	316 SS	316 SS

1. Elastomer material options are specified by the soft goods option in the part number; refer to the "How to Order Section" on page 615 of this catalog.
2. Consult factory for material options not listed above.
3. 316 SS Seat Insert Optional.
4. Teflon is a registered trademark of DuPont Corporation.

ASSEMBLY

Model 1401E Pilot Valve

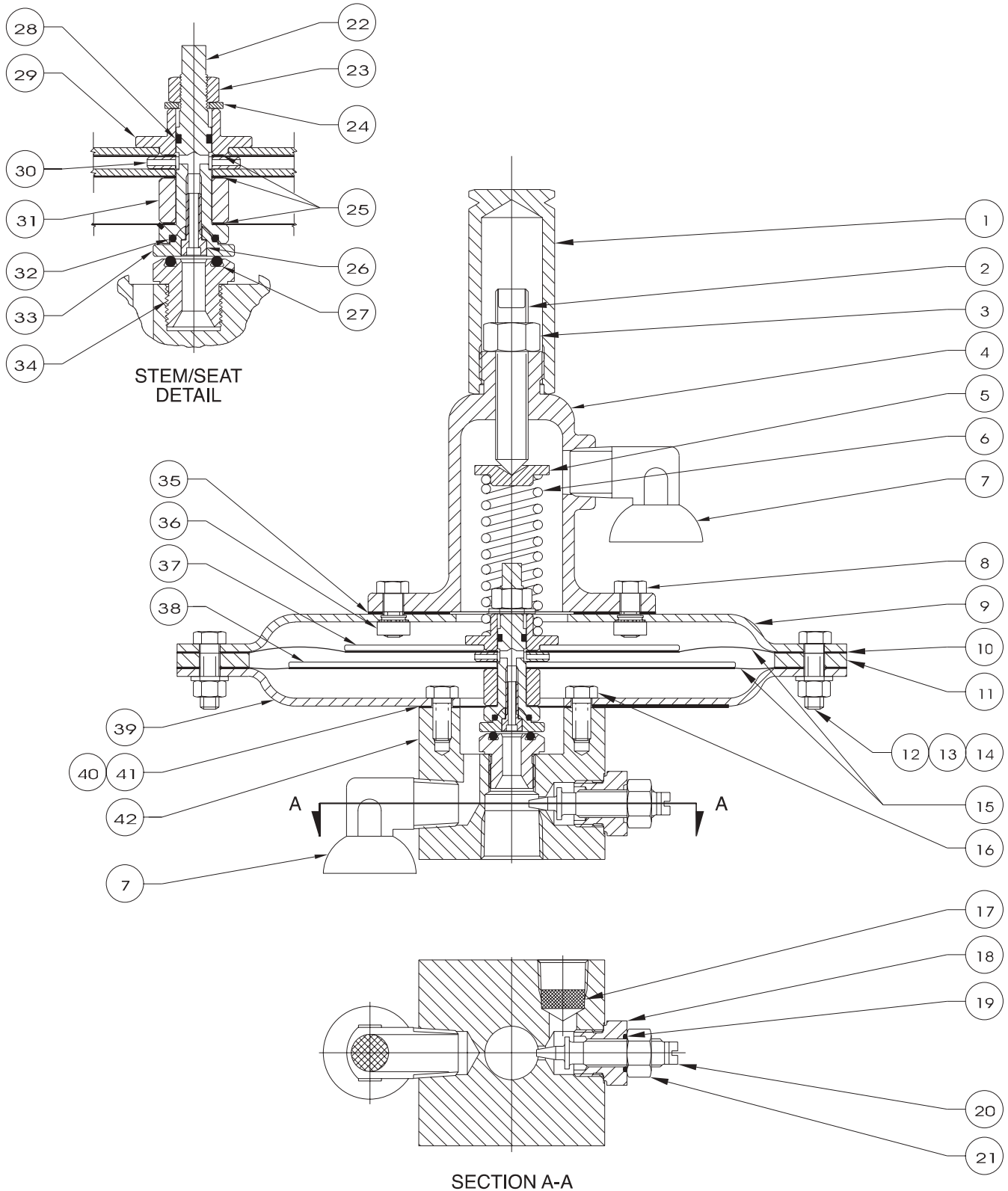

U.S. PATENT NO. 5,163,471

Model 1401E Pilot Valve

Item	Description	Qty.	Materials of Construction	
			All	316 SS
1	Cap, Adjustment Screw	1	316 SS	
2	Screw, Adjustment	1	316 SS	
3	Nut, Hex	1	316 SS	
4	Bonnet, Spring	1	316 SS	
5	Button, Spring	1	316 SS	
6	Spring	1	316 SS (Note 2)	
7	Vent, Breather	2	Plastic	
8	Bolt, Hex	4	316 SS	
9	Case, Diaphragm-Upper	1	316 SS	
10	Gasket, Actuator	1	Teflon® FEP ⁴	
11	Spacer, Actuator Housing	1	316 SS	
12	Bolt Hex	12	316 SS	
13	Nut, Hex	12	316 SS	
14	Washer, Lock	12	316 SS	
15	Diaphragm, Actuator	1	Teflon® FEP ⁴	
16	Bolt, Hex	8	316 SS	
17	Screen, Filter	1	316 SS	
18	Bushing, Blowdown	1	316 SS	
19	O-Ring	1	PTFE	
20	Needle, Blowdown	1	316 SS	
21	Nut, Hex Jam	1	316 SS	
22	Stem	1	316 SS	
23	Nut, Hex	1	316 SS	
24	Washer, Lock	1	316 SS	
25	Washer	1	Teflon® FEP ⁴	
26	Screw, Stem	1	316 SS	
27	O-Ring	1	Note 1	
28	O-Ring	1	Note 1	
29	Guide, Spring	1	316 SS	
30	Spacer, Central	1	316 SS	
31	Spacer, Lower	1	316 SS	
32	O-Ring	1	Note 1	
33	Disc, Stem	1	316 SS	
34	Bushing, Seat	1	316 SS	
35	Gasket, Spring Bonnet	1	Note 1	
36	Nut, Swage	4	304 SS	
37	Plate, Support-Upper	1	316 SS	
38	Plate, Support-Lower	1	316 SS	
39	Case, Diaphragm-Lower	1	316 SS	
40	Diaphragm, Body	1	Teflon® FEP ⁴	
41	Gasket, Body	1	Teflon® FEP ⁴	
42	Body	1	316 SS	

1. Elastomer material options for the pilot valve(s) are specified by the soft goods designation in the "How to Order Section" section on page 615 of this catalog.
2. 17-7 PH SS or Chrome Vanadium for Set Pressure greater than 8 PSI.
3. Consult factory for material options not listed above.
4. Teflon is a registered trademark of DuPont Corporation

OPTIONS

The following options are frequently utilized to reduce vapor emissions, improve serviceability or expand the capabilities of a pilot operated relief valve.

Pilot exhaust piped to discharge header

The exhaust port of the pilot valve may be piped to the outlet body to avoid any vapor emission to the atmosphere.

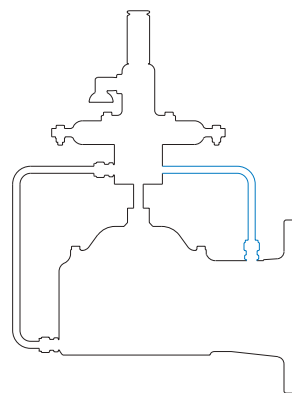

Field Test Connection

A 1/2" NPT(F) connection, block valve and check valve is provided for field testing the pilot valve pressure setting. This is accomplished with an independent pressure source; the check valve prevents back flow into the tank during testing.

Note: Field test connection shown is for a pressure relief valve. Field test connections for vacuum and pressure/vacuum relief are also available.

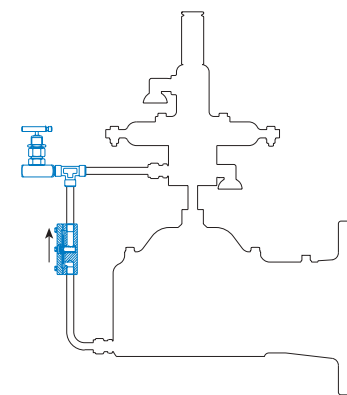

Manual Blowdown

A manually controlled block valve is provided to allow the upper dome pressure to be bled to atmosphere or a process vapor discharge system. If the tank is pressurized, releasing the dome pressure will open the main valve. An electric solenoid valve can be provided for remote blowdown control.

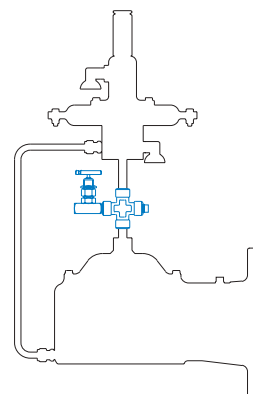

Conical Film Seat

To provide maximum tight shut-off, a patented "Conical Film Seat" is available with Groth Pilot Operated Valves. This unique design will avoid fugitive emissions and will exceed the requirements of "Method 21" in the EPA Regulation, CFR 40, Part 60.

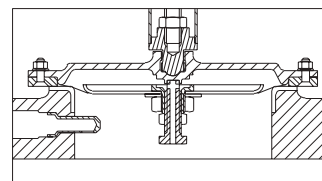

OPTIONS

Remote Sense

Normally Pilot Operated Relief Valves have a total pressure pickup in the main valve inlet. For applications where inlet piping losses are significant, a remote sense connection will assure that the main valve will open fully at the specified pressure regardless of inlet piping pressure loss. Note that the valve sizing must take into account the reduced flow because of the inlet pressure drop. Remote sense is recommended for applications that have entrained particulates. (Tubing/Fittings provided by others.)

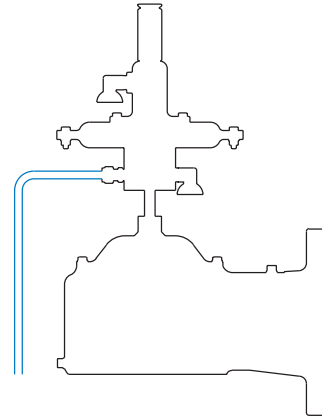

Pilot Supply Filter

An auxiliary filter for the pilot supply line is recommended for services with an unusual amount of foreign particulates. The standard filter is equipped with a 35 micron stainless steel screen that can be easily cleaned.

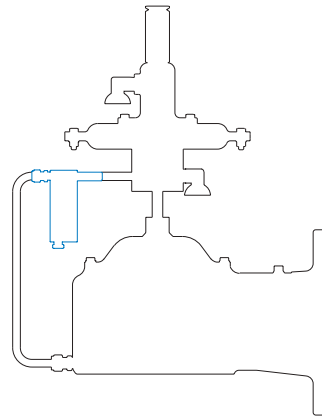

Model 1900 Check Valve

The 1900 Check Valve can also be used in non-relief valve applications such as for corrosive service or low cracking pressure.

- 316 SS Body, Cover and Fasteners
- 0.25" WC Cracking Pressure
- Teflon[®] FEP¹ film & Viton[®] or Kalrez[®] O-Ring
- 1/4" NPT(F) Connections (straight through body)



¹ Teflon is a registered trademark of DuPont Corporation.

Model 1663A Dual Pilot Operated Pressure and Vacuum Relief Valve

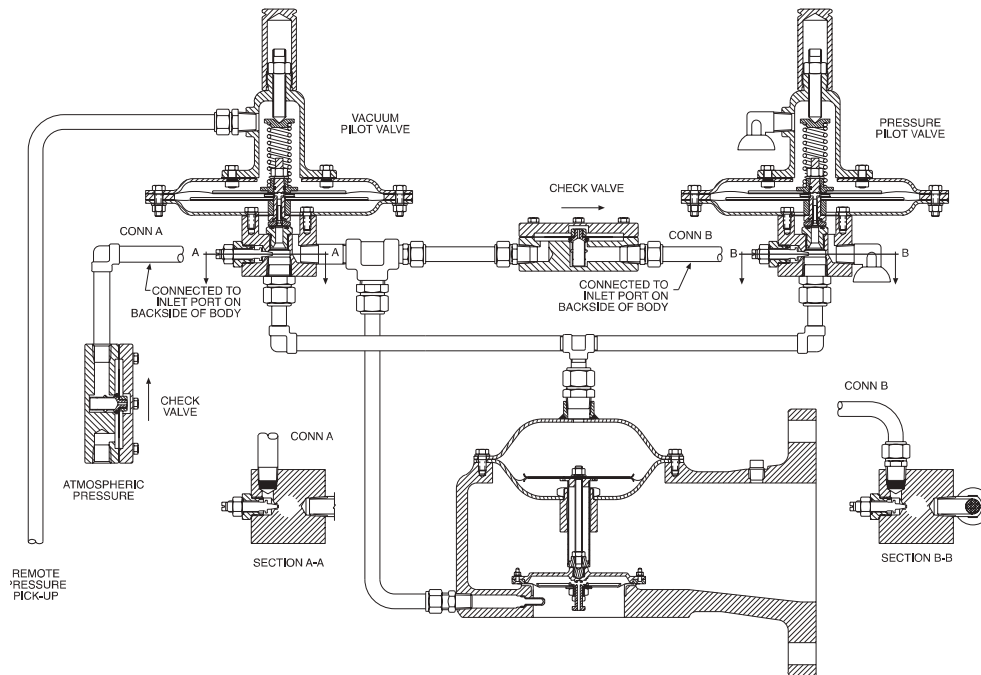

The Model 1663A will be required for pilot operated pressure and vacuum relief when the vacuum setting is greater than the direct actuated vacuum setting of the Model 1661. Minimum vacuum setting for Model 1663A is 3" W.C. and rated capacity is achieved at 10% over-pressure.

Dual pilot valves allow a single relief valve to provide independent settings for pressure and vacuum. Two Groth Model 1900 Check Valves provide isolation of the pressure and vacuum functions. The valve is closed within the set pressure range specified and opens above the positive pressure setting and below the vacuum setting. Backflow prevention protection is not available if the discharge header pressure exceeds tank pressure.

Model 1660A Series Cryogenic Services

- Tested and proven reliable below minus 300° F.
- Snap action at lowest temperatures.
- Tight shut-off with patented conical film seat
- No freeze-up for safe operation.
- All Teflon^{®1} diaphragms

The Groth Series 1660A pilot operated valves are designed to provide the safest and most reliable operation for Cryogenic service. With the incorporation of a Teflon[®] FEP¹ diaphragm and aluminum or 316 SS seat materials, the low temperature does not effect valve operation or valve seat tightness. Tight shut-off and dependable service is assured.



¹ Teflon is a registered trademark of DuPont Corporation.

OPTIONS

The Model 1402 Pilot Valve lowers the effective pressure range of all Groth Pilot Operated Valves to 2.0" WC (depending on valve model, size and materials of construction).

The Model 1402 pilot valve functions as a 4-way valve and the main valve is supplied with a double acting actuator. Below set pressure, the pilot uses tank pressure to pressurize the upper chamber of the actuator and vents the lower chamber. At set pressure, the pilot exhausts the upper chamber and pressurizes the lower chamber, applying sufficient upward force to overcome the weight of the valve stem assembly.

The action is modulating and non-flowing (the pilot only emits vapors while the main valve actuator is being exhausted).

The pilot valve pressure setting is adjustable throughout the range of 2.0" to 8.0" WC. It is used for pressure relief only and is available with all applicable materials and options shown on pages 608-610.

* Patent Protected

Model 1402 Low Set Pilot Operated Relief Valve

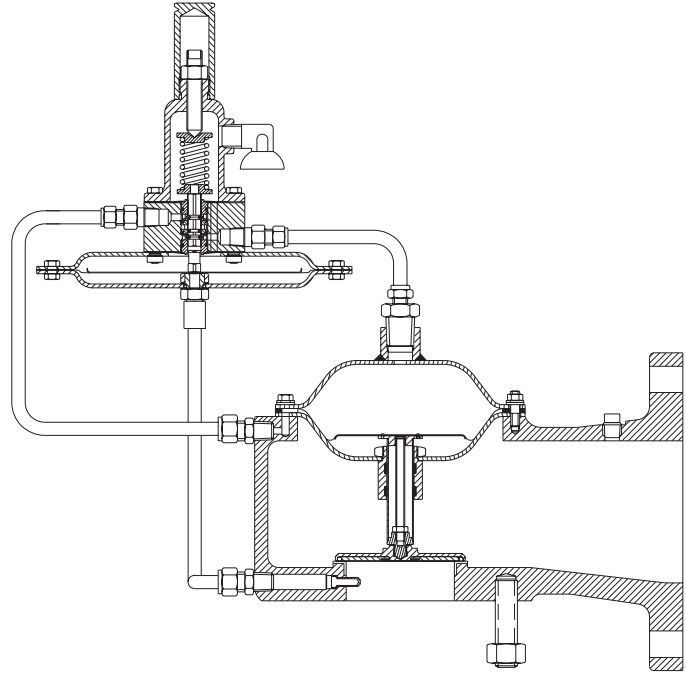

TECHNICAL DATA

MATERIAL OPTION	ALUMINUM	CARBON STEEL	STAINLESS STEEL
Sizes	2" - 12"	2" - 12"	2" - 12"
Pressure Settings	*2" WC to 15 PSIG 5.0 mb to 1.0 BarG	**2" WC to 15 PSIG 5.0 mb to 1.0 BarG	**2" WC to 15 PSIG 5.0 mb to 1.0 BarG
Vacuum Settings	***3" WC to 12 PSIG 7.5 mb to 0.83 BarG	***3" WC to 12 PSIG 7.5 mb to 0.83 BarG	***3" WC to 12 PSIG 7.5 mb to 0.83 BarG
Temperature Limits	-323°F to 300°F -197°C to 150°C	-20°F to 300°F -29°C to 150°C	-323°F to 300°F -197°C to 150°C

* Model 1402 pilot required for settings less than 3" WC [7.5 mb].

** Model 1402 pilot required for settings less than 7" WC [17.2 mb].

*** Direct acting vacuum [Model 1661A] achieves rated capacity at 3.5" WC (8.6 mb)

CAPACITY

Model 1660A, 1661A, 1663A Pilot Operated Valve Pressure Relief Capacity

Set Pressure (P _s)		Air Flow Capacity at 10% Over-pressure 1000 Standard Cubic Feet per Hour at 60° F						
In WC	Oz/Sq In	2"	3"	4"	6"	8"	10"	12"
2.00	1.16	5.46	12.0	20.9	46.8	81.9	129	185
4.00	2.31	7.73	17.1	29.5	66.3	116	182	262
6.00	3.47	9.48	20.9	36.2	81.3	142	223	322
8.00	4.62	11.0	24.2	41.9	94.0	165	258	372
10.00	5.78	12.3	27.1	46.9	105	184	289	417
15.00	8.66	15.1	33.3	57.7	129	227	356	512
20.00	11.6	17.5	38.6	66.8	150	262	412	594
25.00	14.4	19.6	43.3	75.0	168	294	462	666
PSIG								
1		20.7	45.7	79.0	177	311	488	702
2		29.8	65.8	114	255	447	702	1011
3		37.1	81.9	142	318	557	875	1260
4		43.6	96.1	166	373	654	1027	1478
5		49.4	109	189	424	742	1165	1677
6		54.9	121	210	471	824	1294	1863
8		65.1	144	248	557	976	1533	2207
10		74.4	164	284	638	1117	1754	2525
12		83.2	184	318	713	1249	1961	2825
14		91.6	202	350	785	1375	2159	3109
15		95.7	211	366	820	1436	2255	3247

Model 1662A, 1663A Pilot Operated Valve Vacuum Relief Capacity

Set Vacuum (P _s)		Air Flow Capacity at 10% Over-vacuum 1000 Standard Cubic Feet per Hour at 60° F						
In WC	Oz/Sq In	2"	3"	4"	6"	8"	10"	12"
3.00	1.73	6.66	14.7	25.5	57.1	100	157	226
4.00	2.31	7.69	17.0	29.4	65.9	115	181	261
6.00	3.47	9.41	20.8	35.9	80.6	141	222	319
8.00	4.62	10.8	23.9	41.4	93.0	163	256	368
10.00	5.78	12.1	26.7	46.3	104	182	285	411
12.00	6.93	13.3	29.2	50.6	114	199	312	450
16.00	9.27	15.3	33.7	58.3	131	229	360	518
20.00	11.6	17.0	37.6	65.0	146	255	401	578
25.00	14.4	19.0	41.9	72.5	163	285	447	644
PSIG								
1		19.9	44.0	76.1	171	299	470	676
2		27.7	61.0	106	237	415	652	938
3		33.2	73.2	127	284	498	781	1125
4		37.4	82.5	143	320	561	881	1268
5		40.7	89.8	155	349	610	959	1380
6		43.2	95.3	165	370	648	1018	1466
7		45.0	99.3	172	386	675	1060	1527

Model 1661A Direct Actuated Valve Vacuum Relief Capacity

Air Flow Capacity at 3.5" WC (2 oz/in ²) vacuum 1000 Standard Cubic Feet per Hour at 60° F						
2"	3"	4"	6"	8"	10"	12"
6.82	15.1	26.1	58.5	102	161	232

Actual setting depends on size, material and pallet type and varies from 1.0 - 2.0" WC

CAPACITY

Model 1660A, 1661A, 1663A Pilot Operated Valve Pressure Relief Capacity

Set Pressure (P _s)		Air Flow Capacity at 10% Over-pressure 1000 Normal Cubic Meters per Hour at 0° C						
mm WC	mb	2"	3"	4"	6"	8"	10"	12"
50	4.90	0.16	0.35	0.60	1.34	2.35	3.69	5.31
100	9.80	0.22	0.49	0.85	1.90	3.33	5.22	7.52
150	14.7	0.27	0.60	1.04	2.33	4.08	6.41	9.23
200	19.6	0.31	0.69	1.20	2.69	4.72	7.41	10.7
300	29.4	0.42	0.93	1.61	3.62	6.34	9.95	14.3
400	39.2	0.46	1.02	1.76	3.95	6.93	10.9	15.7
500	49.0	0.50	1.11	1.92	4.30	7.52	11.8	17.0
600	58.8	0.54	1.19	2.06	4.63	8.10	12.7	18.3
Bar g								
0.07		0.61	1.35	2.34	5.24	9.18	14.4	20.8
0.10		0.63	1.39	2.40	5.39	9.44	14.8	21.4
0.20		1.05	2.31	3.99	8.96	15.7	24.6	35.5
0.30		1.38	3.04	5.27	11.8	20.7	32.5	46.8
0.40		1.67	3.68	6.38	14.3	25.1	39.4	56.7
0.50		1.93	4.26	7.38	16.6	29.0	45.5	65.6
0.60		2.06	4.55	7.87	17.7	30.9	48.6	69.9
0.70		2.20	4.85	8.40	18.8	33.0	51.8	74.6
0.80		2.34	5.17	8.95	20.1	35.2	55.2	79.5
0.90		2.49	5.49	9.50	21.3	37.3	58.6	84.4
1.00		2.69	5.94	10.3	23.1	40.4	63.5	91.4

Model 1662A, 1663A Pilot Operated Valve Vacuum Relief Capacity

Set Vacuum (P _s)		Air Flow Capacity at 10% Over-vacuum 1000 Normal Cubic Meters per Hour at 0° C						
mm WC	mb	2"	3"	4"	6"	8"	10"	12"
75	7.35	0.19	0.42	0.74	1.65	2.89	4.54	6.53
100	9.80	0.22	0.49	0.85	1.90	3.33	5.24	7.54
150	14.70	0.27	0.60	1.04	2.33	4.08	6.40	9.22
200	19.6	0.31	0.69	1.20	2.69	4.70	7.39	10.6
250	24.5	0.35	0.77	1.34	3.00	5.25	8.25	11.9
300	29.4	0.38	0.84	1.46	3.28	5.75	9.02	13.0
400	39.2	0.44	0.97	1.68	3.78	6.62	10.4	15.0
500	49.0	0.49	1.09	1.88	4.21	7.38	11.6	16.7
600	58.8	0.54	1.19	2.05	4.61	8.07	12.7	18.2
Bar g								
0.07		0.58	1.29	2.23	5.01	8.77	13.8	19.8
0.10		0.69	1.53	2.65	5.94	10.4	16.3	23.5
0.15		0.84	1.85	3.20	7.17	12.6	19.7	28.4
0.20		0.95	2.10	3.63	8.15	14.3	22.4	32.3
0.30		1.12	2.48	4.30	9.64	16.9	26.5	38.2
0.40		1.24	2.75	4.75	10.7	18.7	29.3	42.2
0.50		1.32	2.91	5.04	11.3	19.8	31.1	44.8

Model 1661A Direct Actuated Valve Vacuum Relief Capacity

Air Flow Capacity at 50 mm WC (5.0 mb) vacuum 1000 Normal Cubic Meters per Hour at 0° C						
2"	3"	4"	6"	8"	10"	12"
0.20	0.44	0.76	1.70	2.98	4.68	6.75

Actual setting depends on size, material and pallet type and varies from 1.0 - 2.0" WC

SPECIFICATIONS

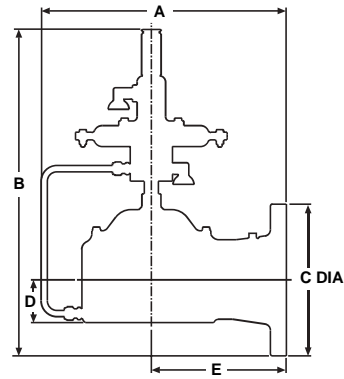

Specifications subject to change without notice. Certified dimensions available upon request.

SIZE		A	B	C	D	E	APPROX. SHIP WT. (Aluminum) Lbs (kg)
INLET	OUTLET	(mm)	(mm)	(mm)	(mm)	(mm)	
2" (50 mm)	3" (80 mm)	11.75" (298)	19.75" (502)	7.50" (190)	2.75" (70)	6.00" (152)	30 (14)
3" (80 mm)	4" (100 mm)	14.75" (375)	21.50" (546)	9.00" (229)	2.53" (64)	8.00" (203)	45 (20)
4" (100 mm)	6" (150 mm)	18.00" (457)	21.75" (552)	11.00" (279)	4.00" (102)	10.00" (254)	56 (25)
6" (150 mm)	8" (200 mm)	21.25" (540)	26.00" (660)	13.50" (343)	4.32" (110)	12.00" (305)	80 (36)
8" (200 mm)	10" (250 mm)	25.50" (648)	28.00" (711)	16.00" (406)	5.31" (135)	14.00" (356)	130 (59)
10" (250 mm)	12" (300 mm)	31.75" (806)	31.50" (800)	19.00" (483)	6.65" (169)	18.00" (457)	170 (77)
12" (300 mm)	16" (400 mm)	36.50" (927)	35.00" (889)	23.50" (597)	8.00" (203)	20.10" (510)	230 (104)

HOW TO ORDER

For easy ordering, select proper model numbers

MODEL # **SIZE** **MATERIAL** **SOFT GOODS** **TYPE** **OPTIONS**

(see notes 1-4)

1660A 02 = 2"
 1661A 03 = 3"
 1662A 04 = 4"
 1663A 06 = 6"
 08 = 8"
 10 = 10"
 12 = 12"

Main Valve
 1 = Alum
 3 = C. Steel
 5 = S.S.

Soft Goods
 B = Buna-N
 E = EPR
 V = Viton®
 K = Kalrez®
 Z = Special

Type
 M = Modulating
 S = SnapAction
 Seat
 R = "O" Ring (see note 4)
 F = Film Seat (see note 5)

Options
 O = No Special Options
 Z = Special Options
 O = No Blowdown or Remote Sense
 B = Manual Blowdown
 R = Remote Sense
 2 = Both Blowdown and Remote Sense
 O = No Pilot to Hdr or Test Connection
 H = Pilot Exhaust Piped to Dischg Header
 T = Field Test Connection
 2 = Both Pilot to Hdr & Test Connection
 O = No Filter or Low Set 1402 Pilot
 F = Pilot Supply Filter
 L = Low Set 1402 Pilot
 2 = Both Filter and Low Set 1402 Pilot

NOTES

- Refer to BOM on pages 606 and 608.
- Diaphragm material for main valve (actuator and film seat) and Pilot Valve are only available in Teflon® FEP¹.
- 300 Series Pilot is standard (see page 608).
- O-ring material is specified by soft goods selection; PTFE is not available.
- FEP Film only; Kalrez O-rings in Pilot Valve (see page 605-8).

EXAMPLE

1 6 6 0 A — 0 6 — 3 — V — R S — 0 0 R 0

Indicates a 6" Model 1660A (pressure relief only) with carbon steel body and "O-Ring" seat using Viton® soft goods with snap action pilot with remote pilot sense connection and no specials.

¹ Teflon is a registered trademark of DuPont Corporation.